

# 1.0 RIDUTTORI PER ELEVATORI A "TAZZE" GEAR UNITS FOR BUCKET ELEVATOR GETRIEBE FÜR "BECHERWERKE"

# RXO./O.

				Pag. Page Seite
1.1	Caratteristiche costruttive	<i>Construction features</i>	Konstruktionsmerkmale	E2
1.2	Livelli di pressione sonora SPL [dB(A)]	<i>Mean sound pressure levels SPL [dB(A)]</i>	Schalldruckpegel SPL [dB(A)]	E3
1.3	Criteri di selezione	<i>Gear unit selection</i>	Auswahlkriterien	E4
1.4	Verifiche	<i>Verification</i>	Überprüfungen	E5
1.5	Designazione riduttori RXO.../...O...	<i>Designation of gear units RXO.../...O...</i>	Bezeichnung der Getriebe RXO.../...O...	E8
1.6	Lubrificazione	<i>Lubrication</i>	Schmierung	E12
1.7	Verifica carichi radiali e assiali	<i>Overhung and thrust load verification</i>	Überprüfung der Radial- und Axialkräfte	E15
1.8	Prestazioni riduttore	<i>Gear unit ratings</i>	Getriebeleistungen	E17
1.9	Momenti d'inerzia	<i>Moments of inertia</i>	Trägheitsmomente	E21
1.10	Motori applicabili	<i>Compatible motors</i>	Applizierbare Motoren	E22
1.11	Dimensioni	<i>Dimensions</i>	Applizierbare Motoren	E24

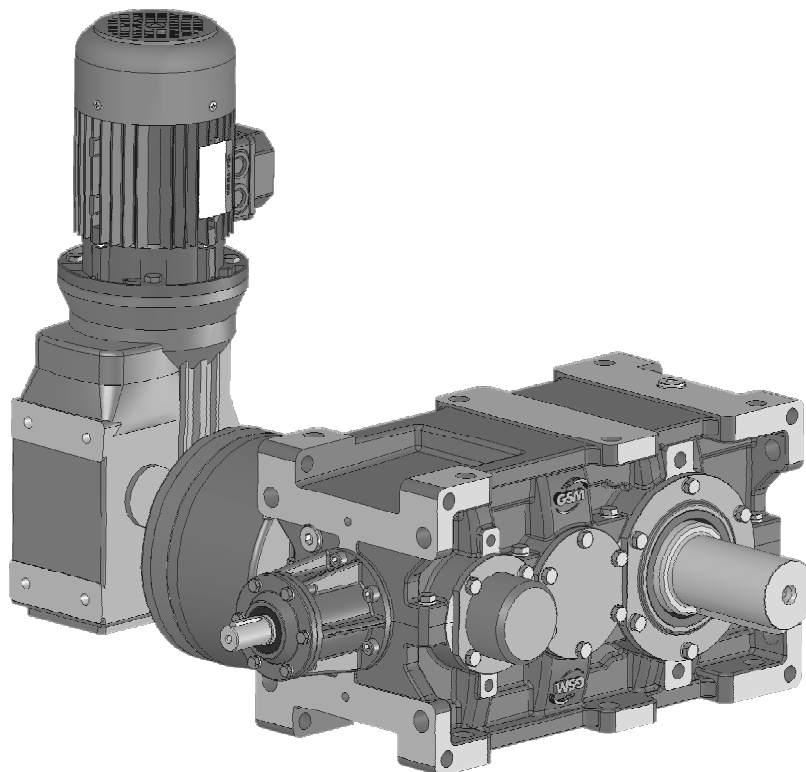

## 1.1 Caratteristiche costruttive

### Generalità

Le dimensioni dei nostri riduttori e i rapporti di trasmissione seguono la serie dei numeri normali (serie di RENARD) Ra 20 UNI 2016.68. I particolari accorgimenti adottati nella costruzione della carcassa esterna conferiscono ai nostri riduttori un'ampia versatilità di montaggio.

La grande scelta disponibile del tipo di esecuzione ci permette di soddisfare anche le esigenze più particolari. L'elevato numero di rapporti di trasmissione,  $i_N = (1.12 \div 1250)$ , consente in alcuni casi di scegliere un riduttore di taglia inferiore. La suddivisione della carcassa in due parti e i coperchi fissati con viti consentono una facile manutenzione.

### Ingranaggi

Gli ingranaggi cilindrici a dentatura elicoidale, sono rettificati sul profilo ad evolvente dopo cementazione, tempra e rinvenimento finale.

Gli ingranaggi conici a dentatura Gleason sono rodati (o rettificati a seconda della grandezza del riduttore), dopo cementazione, tempra e rinvenimento.

L'ottimizzazione geometrica dell'ingranaggio unitamente ad una accurata lavorazione, assicura bassi livelli di rumorosità e garantisce elevati rendimenti:

- 0.95 per un riduttore a due stadi di riduzione
- 0.93 per un riduttore a tre stadi di riduzione
- 0.91 per un riduttore a quattro stadi di riduzione

Tutti gli ingranaggi sono costruiti in:

- 16CrNi4, 20CrNi4, 18NiCrMo5, 20MnCr5 UNI 7846-78

La capacità di carico è stata calcolata a pressione superficiale e a rottura secondo le seguenti normative:

- ISO 6336
- DIN 3990
- AGMA 2001-C95

### Alberi

Gli alberi lenti pieni sono realizzati in 39NiCrMo3 UNI 7845-78. Gli alberi veloci sono realizzati in 16 Cr Ni 4 UNI, 20MnCr5 UNI 7846-78 o in 39 Ni Cr Mo 3 UNI 7845-78. Sono verificati a flessione-torsione con elevato coefficiente di sicurezza. Le estremità d'albero cilindriche sono secondo UNI 6397-68, DIN 748, NF E 22.051, BS 4506-70, ISO/R 775-69, escluso corrispondenza R-S, con foro filettato in testa secondo DIN 1414.. Linguetta secondo UNI 6604-69, DIN 6885 BI, 1-68, NF E 27.656 22.175, BS 4235.1-72, ISO/R 773-69 escluso corrispondenza I.

## 1.1 Construction features

### General Description

*Gear unit dimensions and transmission ratios follow a geometric progression based on the R20 series of preferred (or Renard) numbers in accordance with UNI 2016.68. The casing incorporates special design features to provide the utmost mounting versatility.*

*Our exhaustive range of designs is guaranteed to meet the requirements of every application, no matter how specific. Our broad range of transmission ratios -  $i_N = (1.12 \div 1250)$  and high ratio density frequently allows selection of a smaller size. Split casing design and bolted covers ensure great ease of maintenance.*

### Gearing

*Helical spur gear sets are first case hardened, hardened and tempered and finally their involute profile is ground.*

*Gleason bevel gear sets are first case hardened, hardened and tempered and finally broken in (or ground, depending on gear unit size).*

*Optimal gear geometry and high machining accuracy ensure low noise levels and higher efficiency:*

- 0.95 for double reduction gear units
- 0.93 for triple reduction gear units
- 0.91 for quadruple reduction gear units

*All gear sets are in:*

*- 16CrNi4, 20CrNi4, 18NiCrMo5, 20MnCr5 UNI 7846-78*

*Load capacity is calculated at contact and root bending stress in accordance with the following standards:*

- ISO 6336
- DIN 3990
- AGMA 2001-C95

### Shafts

*Solid output shafts are manufactured from 39NiCrMo3 UNI 7845-78. Input shafts are made from 16 Cr Ni 4 UNI, 20MnCr5 UNI 7846-78 or 39 Ni Cr Mo 3 UNI 7845-78. Shaft calculations incorporate a high safety factor and are validated by bending and torsional stress analyses. Cylindrical shaft ends are in accordance with UNI 6397-68, DIN 748, NF E 22.051, BS 4506-70, ISO/R 775-69, excluding section R-S, with centre tapped hole at shaft end to DIN 1414. Keys are in accordance with UNI 6604-69, DIN 6885 BI, 1-68, NF E 27.656 22.175, BS 4235.1-72, ISO/R 773-69 excluding section I.*

## 1.1 Construction features

### Allgemeines

Die Baugrößen und Übersetzungen unserer Getriebe sind der normalen Nummerreihe (RENARD Reihe) Ra 20 UNI 2016.68 gemäß ausgelegt.

Die besonderen Konstruktionsmerkmale der Gehäuse ermöglichen die Montage unserer Getriebe in den unterschiedlichsten Einbaulagen.

Das breite Angebot an Ausführungstypen versetzt uns in die Lage, auch den ausgefallenen Anforderungen unserer Kunden entsprechen zu können.

Die zahlreichen Übersetzungsverhältnisse,  $i_N = (1.12 \div 1250)$  räumen in einigen Fällen die Möglichkeit ein, ein kleineres Getriebe wählen zu können. Die zweiteiligen Gehäuse und die mit Schrauben befestigten Deckel erlauben eine einfache Wartung.

### Zahnräder

Das Evolventenprofil der Stirnrädergetriebe mit Schrägverzahnung wird nach dem Einsatzhärten, dem Abschrecken und dem Anlassen entsprechend geschliffen.

Die Kegelzahnräder mit Gleason-Verzahnung sind bereits eingelaufen (oder in Abhängigkeit der Getriebegröße geschliffen), dies erfolgt nach dem Einsatzhärten, Abschrecken und Anlassen. Die geometrische Optimierung des Zahnrads verbunden mit einer akkuraten Bearbeitung gewährleistet niedrige Geräuschentwicklung und einen hohen Wirkungsgrad:

- 0.95 bei Getrieben mit zwei Getriebestufen
- 0.93 bei Getrieben mit drei Getriebestufen
- 0.91 bei Getrieben mit vier Getriebestufen

Alle Zahnräder werden aus folgendem Material gefertigt:

- 16CrNi4, 20CrNi4, 18NiCrMo5, 20MnCr5 UNI 7846-78

Die Belastbarkeit wurde auf Oberflächenbruch und Bruch den folgenden Richtlinien gemäß berechnet:

- ISO 6336
- DIN 3990
- AGMA 2001-C95

### Wellen

Die vollen Abtriebswellen sind aus 39NiCrMo3 UNI 7845-78 realisiert. Die Antriebswellen dagegen aus 16 Cr Ni 4 UNI, 20MnCr5 UNI 7846-78 oder aus 39 Ni Cr Mo 3 UNI 7845-78. Sie werden unter Berücksichtigung eines hohen Sicherheitskoeffizienten auf Biegung-Windung getestet. Die Enden der zylindrischen Wellen entsprechen den Normen UNI 6397-68, DIN 748, NF E 22.051, BS 4506-70, ISO/R 775-69, ausgenommen Zuordnung R-S, mit Gewindebohrung in der Wellenspitze DIN 1414. Die Federkeile entsprechen UNI 6604-69, DIN 6885 BI, 1-68, NF E 27.656 22.175, BS 4235.1-72, ISO/R 773-69, ausgenommen Zuordnung I.

**Cuscinetti**

Tutti i cuscinetti sono del tipo a rulli conici o a rulli orientabili, di elevata qualità e dimensionati per garantire una lunga durata se lubrificati con il tipo di lubrificante previsto a catalogo.

**Carcassa**

La carcassa è ottenuta per fusione in GG 250 ISO 185 fino alla grandezza 820. Le altre grandezze sono in acciaio Fe430 EN UNI 10025 composto elettrosaldato e disteso.

I particolari accorgimenti adottati nel disegno della struttura permettono di ottenere un' elevata rigidità.

**1.2 Livelli di pressione sonora SPL [dB(A)]**

Valori normali di produzione del livello medio di pressione sonora SPL (dB(A)) a velocità in entrata di 1450 min<sup>-1</sup> (tolleranza +3 dB(A)). Valori misurati ad 1 m dalla superficie esterna del riduttore ed ottenuti su elaborazione di prove sperimentali eseguite. Per raffreddamento artificiale con ventola sommare ai valori di tabella: +2 dB(A) per ogni ventola. Per entrata ad un numero di giri diverso sommare i valori come in tabella. Per particolari esigenze è possibile fornire riduttori con livello medio di pressione sonora ridotto.

**Bearings**

*All bearings are high quality taper or self-aligning roller bearings suitably sized to ensure long service life provided the approved lubricants indicated in this catalogue are used.*

**Casing**

*Casings up to size 820 are cast from GG 250 ISO 185 cast iron. All other sizes use casings fabricated from electrically welded stress relieved Fe430 steel EN UNI 10025.*

*Casing design incorporates special arrangements to provide superior rigidity.*

**1.2 Mean sound pressure levels SPL [dB(A)]**

*Noise levels are mean sound pressure levels SPL (dB(A)) and refer to normal operation at an input speed of 1450 rpm (tolerance +3 dB (A)). Measurements are taken at 1 m from the external surface of the gear unit and ratings are obtained by processing test data. For fan-cooled applications, add 2dB (A) to table values for each fan. For different input speeds, add the appropriate values indicated in the table below. Gear units with lower noise levels to suit particular needs are available on request.*

**Lager**

Bei allen Lagern handelt es sich um hochqualitative Kegelrollenlager mit orientierungsfähigen Rollen und in Maßen, die so ausgelegt sind, dass sie bei Einsatz der gemäß Katalogangaben vorgesehenen Schmiermittel eine lange Lebensdauer garantieren.

**Gehäuse**

Die Gehäuse der Getriebe bis Baugröße 820 werden im Gussverfahren aus GG 250 ISO 185 gewonnen; die anderen Baugrößen sind aus elektroverschweißtem und entspanntem Kombistahl Fe430 EN UNI 10025 realisiert.

Die besonderen beim Entwurf der Struktur berücksichtigten Vorkehrungen verleihen ihr eine besondere Steifheit.

**1.2 Schalldruckpegel SPL [dB(A)]**

Normale Werte des durchschnittlichen Schalldruckpegels SPL (dB(A)) bei einer Antriebsdrehzahl von 1450 U/min (Toleranz +3 dB(A)). Werte, die aus den Auswertungen der erfolgten experimentellen Tests, bei denen die Messung in 1 m Entfernung von der Getriebeoberfläche erfolgte, resultieren.

Bei Vorliegen einer Zusatzluftkühlung durch Lüfter muss ein Korrekturwert von +2 dB(A) pro Lüfterrad zum Tabellenwert addiert werden. Bei abweichender Antriebsdrehzahl sind die Werte gemäß Tabellenangaben zu addieren. Im Fall besonderer Anforderungen können Getriebe mit einem reduzierten durchschnittlichen Schalldruckpegel geliefert werden.



	RX02 - RXV2	
	i ≤ 50	i > 50
802	73	68
804	74	69
806	76	71
808	77	72
810	79	74
812	80	75
814	82	77
816	84	79
818	86	81
820	88	83
822	90	85
824	92	87
826	94	89
828	96	91

n <sub>1</sub> [min <sup>-1</sup> ]	2750	2400	2000	1750	1000	750	500	350
Δ SPL [dB(A)]	8	6	4	2	-2	-3	-4	-6

### 1.3 Criteri di selezione

#### Fattore di servizio - Fs

Il fattore di Servizio Fs dipende:

- a) dalle condizioni di applicazione
- b) dalla durata di funzionamento h/d
- c) avviamenti /ora
- d) dal grado di affidabilità o margine di sicurezza voluto.

Il fattore di servizio assunto per i riduttori per Elevatori a "Tazze" è generalmente  $F_s=1.5$ . Dove il funzionamento è continuo sino ad arrivare a 2 o 3 turni giornalieri il fattore di servizio è rispettivamente  $F_s=1.75$  e  $F_s=2.0$ .

Le potenze e i momenti torcenti indicati a catalogo nominali sono validi per  $F_s=1$ .

#### Procedura di selezione

##### 1) SCELTA RIDUTTORE PRIMARIO

Conosciuti i dati dell' applicazione calcolare:

- $i = n_1/n_2$  rapporto richiesto
- $T_2$  Momento Torcente sull'albero uscita
- $P_1$  potenza motrice necessaria (Nel calcolo si consideri un rendimento di 0.96).

Scegliere il rapporto, la grandezza del riduttore primario verificando :

- a) la potenza nominale:  
 $P_N \geq P_1 \times F_s$   
oppure

- b) la coppia nominale:  
 $T_N \geq T_2 \times F_s$

Infine scegliere l' esecuzione grafica, la forma costruttiva e verificare le dimensioni del riduttore e di eventuali accessori o particolari estremità.

### 1.3 Gear unit selection

#### Service factor - Fs

Service factor  $F_s$  is determined on the basis of:

- a) operating conditions of application
- b) operation per day (h/d)
- c) starts and stops per hour
- d) desired reliability or safety factor.

Usually, a service factor  $F_s=1.5$  is selected for bucket elevator gear units. Service factors for continuous duty up to two or three daily shifts are  $F_s=1.75$  and  $F_s=2.0$ , respectively.

Power and torque ratings stated in the catalogue refer to service factor  $F_s=1$ .

#### Selection procedure

##### 1) MAIN GEAR UNIT SELECTION

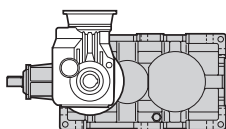

Locate application information and determine:

- required ratio  $i = n_1/n_2$
- torque at output shaft  $T_2$
- power  $P_1$  required to drive load (Please consider 0.96 efficiency per stage in your calculations).

Select ratio and size of main gear unit and check:

- a) nominal power:  
 $P_N \geq P_1 \times F_s$   
or

- b) nominal torque:  
 $T_N \geq T_2 \times F_s$

Select shaft arrangement and design configuration and then check the dimensions of gear unit and any accessories or particular input/output configurations you have selected.

### 1.3 Auswahlkriterien

#### Betriebsfaktor - Fs

Der Betriebsfaktor  $F_s$  hängt von folgenden Kriterien ab:

- a) Einsatzbedingungen
- b) Betriebsdauer h/d
- c) Anläufe / Stunde
- d) Zuverlässigkeitsgrad oder gewünschter Sicherheitsbereich.

Der bei den Getrieben für "Becherwerk" angewendete Betriebsfaktor entspricht allgemein  $F_s=1.5$ . Beim Einsatz im Dauerbetrieb mit 2 bis 3 Tagesschichten ist der Betriebsfaktor jeweils  $F_s=1.75$  und  $F_s=2.0$ .

Die im Katalog angegebenen Nennleistungen und -drehmomente sind für  $F_s=1$  gültig.

#### Auswahlverfahren

##### 1) WAHL DES HAUPTGETRIEBES

Sind die Daten der Applikation bekannt, ist wie folgt zu berechnen:

- $i = n_1/n_2$  erforderliche Übersetzung
- $T_2$  Drehmoment an Abtriebswelle
- $P_1$  erforderliche Antriebsleistung (bei Berechnung einen Wirkungsgrad von 0,96 berücksichtigen).

Die Übersetzung und die Größe des Hauptgetriebes wählen und dabei prüfen:

- a) Nennleistung:  
 $P_N \geq P_1 \times F_s$   
oder

- b) Nenndrehmoment  
 $T_N \geq T_2 \times F_s$

Schließlich die grafische Ausführung sowie die Bauform wählen und die Maße des Getriebes und des Zubehörs oder besondere Wellenenden überprüfen.

2) SCELTA "AUXILIARY DRIVE"

2) AUXILIARY DRIVE SELECTION

2) WAHL "AUXILIARY DRIVE"

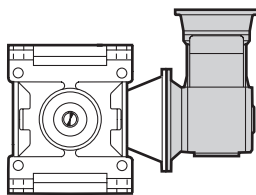

Calcolare la potenza motrice  $P_2$  necessaria utilizzando la seguente formula:

Determine required drive power  $P_2$  by the following formula:

Unter Anwendung der folgenden Formel die erforderliche Antriebsleistung  $P_2$  berechnen:

$$P_2 = P_1 \cdot K_2 \quad [\text{kW}]$$

Il valore di  $k_2$  si ricava dalla tabella delle prestazioni.  
Infine determinare il rapporto di riduzione  $i_{es}$  corrispondente al rapporto di riduzione del riduttore primario selezionato al punto 1).

Look up  $k_2$  in the rating tables.  
Finally, determine reduction ratio  $i_{es}$  to suit the reduction ratio of the main gear unit selected at step 1).

Der Wert  $k_2$  kann der Leistungstabelle entnommen werden.  
Schließlich das Übersetzungsverhältnis  $i_{es}$  des gemäß Punkt 1) gewählten Hauptgetriebes bestimmen.

**N.B.**

La selezione è conforme se e solo se la velocità  $n_1$  del primario e del auxiliary drive sono di 1450 rpm.

**NOTE**

Speed  $n_1$  of both main and auxiliary drive gear units must be 1450 rpm; this is a pre-requisite for correct selection.

**HINWEIS**

Die Wahl ist nur dann konform, wenn die Drehzahl  $n_1$  des Hauptantriebs und des Nebenantriebs 1450 UpM beträgt.

**1.4 Verifiche**

1) Compatibilità dimensionale con ingombri disponibili (es diametro del tamburo) e delle estremità d'albero con giunti, dischi o pulegge.

**1.4 Verification**

1) Ensure that dimensions are compatible with space constraints (for instance, drum diameter) and shaft ends are compatible with any couplings, discs or pulleys to be used.

**1.4 Überprüfungen**

1) Kompatibilità der Abmessungen mit verfügbaren Maßen (z.B. Trommeldurchmesser) und der Wellenenden mit den Kupplungen, Scheiben oder Riemenscheiben.

2) Ammissibilità di carichi radiali e/o assiali esterni; i carichi radiali  $F_{r1}$  e  $F_{r2}$  ammissibili sono riportati nelle tabelle delle prestazioni e si intendono applicati in mezzzeria dell'estremità dell'albero. Per condizioni diverse consultare la pag. E15.

2) Check that overhung and/or thrust loads do not exceed permissible loads; permissible overhung loads  $F_{r1}$  and  $F_{r2}$  at midpoint of shaft extension are listed in the rating tables. For any conditions other than those listed above, please read page. E15.

2) Zulässigkeit der externen Radial- und/oder Axialkräfte; die zulässigen Radialkräfte  $F_{r1}$  und  $F_{r2}$  werden in den Leistungstabellen angegeben und verstehen sich als auf die Wellenmitte wirkend. Im Fall anderer Bedingungen verweisen wir auf Seite E15.

3) Massimo sovraccarico nel caso di:

- inversioni di moto per effetti inerziali,
- commutazioni da bassa ad alta polarità,
- avviamenti e frenature a pieno carico con grandi momenti d'inerzia (soprattutto nel caso di bassi rapporti),
- sovraccarichi, urti od altri effetti dinamici, deve essere verificata la condizione:

3) Determine maximum overload in the event of:

- reversing due to inertia,
- switching from low to high polarity,
- starts and stops under full load with high moment of inertia (this is especially important for low ratios),
- overload, shock load or other dynamic load conditions, and determine whether this condition is verified:

3) Maximale Überlast im Fall von:

- Drehrichtungs-Umkehr aufgrund von Trägheitseffekten,
- Umschaltung von niedriger auf hohe Polarität,
- Anläufe und Bremsungen unter Vollast mit hohen Trägheitsmomenten (vor allem bei niedrigen Übersetzungsverhältnissen),
- Überlasten, Stöße oder andere dynamische Effekte.

$$T_{max} \leq 2 \times T_N$$

$$T_{max} \leq 2 \times T_N$$

Es muss die Bedingung:

$$T_{max} \leq 2 \times T_N$$



5) Verifica Posizione di montaggio

5) Check mounting position

6) Prüfen der Einbaulage

6) Adeguatazza della potenza termica del riduttore:

Nel caso di solo riduttore in servizio continuo o intermittente gravoso in ambienti a temperatura elevata e/o con difficoltà di scambio termico (es. acciaierie) è necessario verificare che la potenza termica nominale corretta dai fattori sia superiore alla potenza assorbita come evidenziato nella seguente equazione:

6) Ensure gear unit thermal power is suitable for the application:

If a gear unit is to be used in continuous or intermittent duty in environments where high temperatures and/or poor heat exchange are encountered (such as steelworks), check to ensure the thermal power obtained after application of the relevant correction factors is greater than absorbed power, i.e. that the following condition is verified:

7) Angemessene thermische Grenzleistung des Getriebes:

Wird ein einziges Getriebe im Dauerbetrieb oder harten Schaltbetrieb in einer Umgebung mit hohen Temperaturen und/oder einem schwierigen Wärmeaustausch (z.B. Stahlwerke) eingesetzt, muss geprüft werden, dass die thermische, von den jeweiligen Faktoren korrigierte Nennleistung über der Aufnahmeleistung liegt, wie es in der folgenden Gleichung dargestellt wird:

$$P_1 \leq P_{tN} \cdot fa \cdot fd \cdot fp \cdot ff \quad [kW]$$

Dove:

$P_{tN}$  = potenza termica nominale  
 $fa$  = fattore correttivo dell'altitudine  
 $fd$  = fattore correttivo del tempo di lavoro  
 $fp$  = fattore correttivo della temperatura ambiente  
 $ff$  = fattore correttivo di aerazione con ventola

Where:

$P_{tN}$  = thermal power rating  
 $fa$  = altitude factor  
 $fd$  = operation time factor  
 $fp$  = ambient temperature factor  
 $ff$  = fan cooling factor

Hier ist:

$P_{tN}$  = thermische Nennleistung  
 $fa$  = Höhenkorrekturfaktor  
 $fd$  = Korrekturfaktor der Arbeitszeit  
 $fp$  = Korrekturfaktor der Umgebungstemperatur  
 $ff$  = Korrekturfaktor der Belüftung durch Lüfter

Qualora tale condizione non sia verificata occorre sostituire la ventola con un gruppo di raffreddamento con scambiatore di calore. Per selezionare il gruppo di raffreddamento adeguato occorre determinare la  $P_{ta}$  necessaria:

If this condition is not verified, opt for a heat exchanger instead of fan cooling. To select a suitable cooling unit, you need to determine required  $P_{ta}$ :

Sollte diese Bedingung nicht gegeben sein, muss anstelle des Lüfters ein Kühlaggregat mit Wärmeaustauscher appliziert werden. Vor der Wahl des angemessenen Kühlaggregats muss zunächst die erforderliche  $P_{ta}$  bestimmt werden:

$$P_{ta} \leq P_1 - (P_{tN} \cdot fa \cdot fd \cdot fp) \quad [kW]$$

dove:

$P_{ta}$  = potenza termica addizionale

Dopo avere selezionato il gruppo di raffreddamento, ripetere la verifica aggiungendo alla precedente il valore massimo di  $P_{tamax}$  del range identificato espresso in tabella, adeguato con i coefficienti correttivi di temperatura acqua e aria:

Where:

$P_{ta}$  = additional thermal power required

After selecting the cooling unit, check that the following condition is satisfied; as you can see, it considers the upper limit value  $P_{tamax}$  of the resulting tabulated range adjusted using the water and air temperature correction factors:

Hier ist:

$P_{ta}$  = thermische Zusatzleistung

Nach erfolgter Wahl der Kühlgruppe, die Kontrolle wiederholen und dabei dem vorausgehenden Wert dem max. Wert des  $P_{tamax}$  des in der Tabelle angegebenen Bereichs zurechnen und durch die Korrektorkoeffizienten der Wasser- und Lufttemperatur anpassen:

$$P_1 \leq (P_{tN} \cdot fm \cdot fa \cdot fd \cdot fp) + (P_{tamax} \cdot fw \cdot fc) \quad [kW]$$

dove:

$P_{tamax}$  = potenza termica addizionale del range identificato espresso in tabella

$fw$  = coefficiente relativo alla temperatura dell'acqua (esclude  $fc$ )  
 $fc$  = coefficiente relativo alla temperatura dell'aria (esclude  $fw$ )

La  $P_{tN}$  è riferita ad un ambiente industriale aperto; nel caso di ambienti confinati scarsamente aerati consultarci.

Where:

$P_{tamax}$  = additional thermal power required obtained from resulting tabulated range

$fw$  = water temperature factor (excludes  $fc$ )  
 $fc$  = air temperature factor (excludes  $fw$ )

$P_{tN}$  refers to an open space industrial environment; in the event of a confined space environment with poor ventilation, please contact the factory.

Hier ist:

$P_{tamax}$  = thermische Zusatzleistung des identifizierten, in der Tabelle angegebenen Bereichs

$fw$  = Koeffizient bezüglich der Wassertemperatur (schließt  $fc$  aus)  
 $fc$  = Koeffizient bezüglich der Lufttemperatur (schließt  $fw$  aus)

Die  $P_{tN}$  bezieht sich immer auf einen Einsatz im industriellen offenen Umfeld; sollten Umgebungen mit geringer Belüftung daran angrenzen, bitten wir Sie, sich mit uns in Verbindung zu setzen.

$P_{tN}$

	802	804	806	808	810	812	814	816	818	820	822	824	826	828	830	832
RX02	24	30	40	52	65	82	102	127	165	205	248	306	368	445	—	—

**fa**

Fattore correttivo dell'altitudine  
Altitude factor  
Korrekturwert der Höhe

m	0	750	1500	2250	3000
<b>fa</b>	1	0.95	0.9	0.85	0.81

**fd**

Fattore correttivo del tempo di lavoro  
Operation time factor  
Korrekturwert der Betriebszeit

S3%	<b>fd</b>
100	1
80	1.05
60	1.15
40	1.35
20	1.8

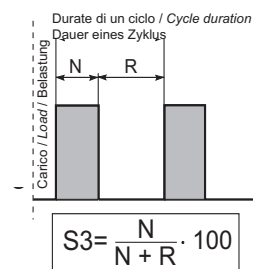

**fp**

Fattore correttivo della temperatura ambiente.  
Ambient temperature factor.

Korrekturfaktor der Umgebungstemperatur

Temperatura ambiente Ambient temperature Umgebungstemperatur	50 °C	40 °C	30 °C	20 °C	10 °C	0 °C
<b>fp</b>	0.63	0.75	0.87	1	1.12	1.25

**ff**

Il fattore correttivo ff della potenza termica che tiene conto dell'effetto refrigerante della ventola assume in accordo con le norme AGMA 6010.E88 i valori riportati nella tabella 8. L'impiego è limitato alle velocità maggiori o uguali a 700 min<sup>-1</sup>.

Cooling fan factor ff reported in table 8 are in accordance with AGMA 6010.E88 and can be used directly to adjust thermal power to reflect the use of a cooling fan. These factors must only be used for speeds equal to 700 rpm and higher.

In Übereinstimmung mit den Normen AGMA 6010.E88 nimmt der Korrekturwert ff der thermischen Grenzleistung, der den Kühleffekt des Lüfters berücksichtigt, die in der Tabelle 8 angegebenen Werte an. Der Einsatz beschränkt sich auf die Drehzahlen die 700 min<sup>-1</sup> betragen oder darüber liegen.

Tipo Type Typ	Tipo ventola Fan type Lüfertyp	Note Notes Hinweise	<b>ff</b>
<b>RXO RXV</b>	VE	—	1.7

**Pta** [kW]

Potenza termica addizionale

Additional thermal power

Thermische Zusatzgrenzleistung

Raffreddamento con scambiatore acqua-olio (Tacqua=15°C) Cooling by air-oil exchanger (Tair=20°C) Kühlung durch Wasser-/Ölaustauscher (TWasser=15°C)	
Gruppo Size Größe	<b>RXO2 RXV2</b>
1	≤ 45
2	46 ÷ 78
3	79 ÷ 116
4	117 ÷ 355
5	356 ÷ 680

Raffreddamento con scambiatore aria-olio (Taria=20°C) Cooling by air-oil exchanger (Tair=20°C) Kühlung durch Luft-/Ölaustauscher (TLuft=20°C)	
Gruppo Size Größe	<b>RXO2 RXV2</b>
1	≤ 75
2	76 ÷ 140
3	141 ÷ 298
4	299 ÷ 386
5	387 ÷ 680

**fw**

Coefficiente relativo alla temperatura dell'acqua  
Water temperature factor  
Koeffizient bezüglich der Wassertemperatur

Twater	15°C	20°C	25°C	30°C
<b>fw</b>	1	0.85	0.7	0.6

**fc**

Coefficiente relativo alla temperatura dell'aria  
Air temperature factor  
Koeffizient bezüglich der Lufttemperatur

Tair	15°C	20°C	25°C	30°C	35°C	40°C
<b>fc</b>	1,12	1	0.88	0.75	0.65	0.5

**1.5 Designazione riduttori RXO.../...O...**

Nel riduttore con sistema AUXILIARY DRIVE deve essere indicata la designazione del riduttore secondario e la designazione del riduttore primario come indicato di seguito.

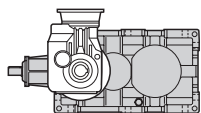

**1.5 Designation of gear units RXO.../...O...**

For gear units with AUXILIARY DRIVE system, both main and auxiliary gear units must be designated as follows.

**1.5 Bezeichnung der Getriebe RXO.../...O....**

Bei einem Getriebe mit dem System AUXILIARY DRIVE muss die Bezeichnung des Nebengetriebes und die des Hauptgetriebes gemäß nachstehenden Angaben angegeben werden.

	[1*]	[2*]	[3*]	[4*]	[5*]	[6*]	[7*]	[8*]	[9*]	[10*]	[11*]	[12*]	[13*]
<b>RX</b>	<b>O</b>	<b>2</b>	<b>802</b>	<b>ABU</b>	<b>28</b>	<b>ECE</b>	<b>VE</b>	<b>ARDB</b>	–	<b>N</b>	<b>M1</b>		<b>O 71</b>
Macchina Range Version	Posizione assi Centreline orientation Achsenpositionen	N° stadi No. of Reductions Stufen	Grandezza Size Baugröße	Esecuzione grafica Shaft arrangement Grafische Ausführung	<i>i</i>	Estremità entrata Input configuration Wellenende – Antrieb	Ventole raffreddamento Cooling fans Lüfter	Antiretro Backstop Rücklaufsperre	Materiale carcassa Housing material Gehäuse material	Estremità uscita Output configuration Wellenende – Abtrieb	Posizione di montaggio Mounting position Einbaulage	Opzioni Options Optionen	Entata Supplementare Auxiliary drive Zusatzantrieb
<b>RX</b>	<b>O V</b>	<b>2</b>	<b>802 ... 828</b>	<b>A - AS B - BS C1-C2 C1D-C1S C2D-C2S</b>		<b>ECE PAM.. PAM..G ECES PAM..S</b>	<b>VE</b>	<b>ARSB ARSN ARDB ARDN</b>	– <b>AGS</b>	<b>N C UB B FD Fn D</b>	<b>M1</b>		

[13*]	[14*]	[15*]	[16*]	[17*]	[18*]
<b>O</b>	<b>71</b>	<b>2</b>	<b>DX</b>	<b>506</b>	<b>PAM132</b>
Tipo Entrata Supplementare Auxiliary drive type Typ – Zusatzantrieb	Grandezza Size Baugröße	Asse Riferimento Reference Centreline Bezugsachse	Posizione Position Position	<i>i</i> <sub>es</sub>	Estremità entrata Input configuration Antriebswellenende
<b>O</b>	<b>71</b>	<b>2</b>	<b>DX</b>	<b>506</b>	<b>PAM..</b>

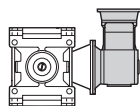

**Designazione motore elettrico**

Se è richiesto un motoriduttore completo di motore è necessario riportare la designazione di quest'ultimo. A tale proposito consultare il ns. catalogo dei motori elettrici Electronic Line.

**Electric motor designation**

For applications requiring a gearmotor, motor designation must be specified. To this end, please refer to our Electronic Line electric motor catalogue.

**Bezeichnung des Elektromotors**

Wird ein Getriebemotor komplett mit Elektromotor angefordert, müssen dessen Daten angegeben werden. Diesbezüglich verweisen wir auf unseren Katalog der Elektromotoren "Electronic Line".

**[\*1] Posizione assi**

**[\*1] Centreline orientation**

**[\*1] Achsenposition**

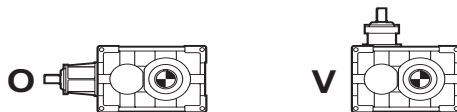

**[\*2] N° stadi**

**[\*2] No. of Reductions**

**[\*2] Anzahl der Stufen**

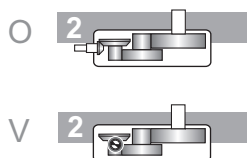

**[\*4] Esecuzione grafica**

(vedi pagine dimensionali)

**[\*4] Shaft arrangement**

(please refer to dimension pages)

**[\*4] Grafische Ausführung**

(siehe Seite mit Maßangaben)

**[\*5] Rapporto di riduzione i**

(Vedi tabelle prestazioni)

**[\*5] Reduction ratio i**

(See rating tables)

**[\*5] Übersetzungsverhältnis i**

(Siehe Leistungstabelle)



**[\*6] Estremità entrata**

**[\*6] Input configuration**

**[\*6] Wellenende - Antrieb**

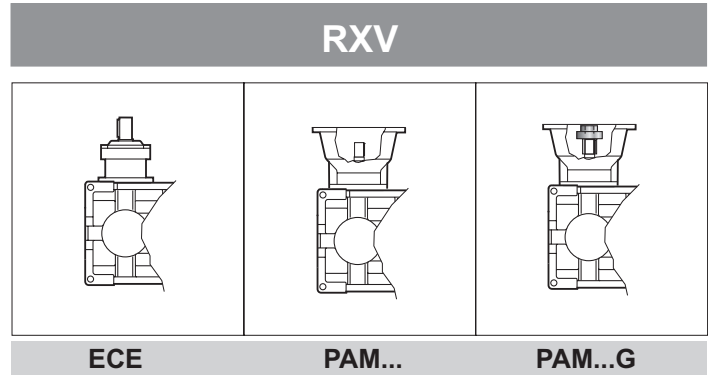
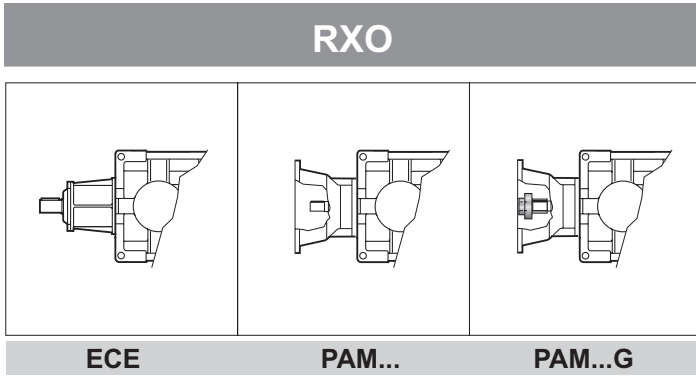

<b>ECE</b>	Entrata con albero pieno	<i>Solid input shaft</i>	Antrieb mit Vollwelle
<b>PAM..</b>	Con campana senza giunto	<i>Motor bell without coupling</i>	mit Glocke ohne Kupplung
<b>PAM..G</b>	Con campana e giunto	<i>Motor bell and coupling</i>	mit Glocke und Kupplung
<b>ECES</b>	Entrata con estremità speciale	<i>Special input shaft end</i>	Antrieb mit speziellem Wellenende
<b>PAM..S</b>	Accoppiamento speciale	<i>Special coupling</i>	Spezialpassung (auf Anfrage erhältlich)

**[\*7] Ventole di raffreddamento**

**[\*7] Cooling fans**

**[\*7] Kühllüfterräder**

Fare riferimento al capitolo accessori (G)

Please refer to accessories chapter (G)

Siehe Kapitel "Zubehör" (G)

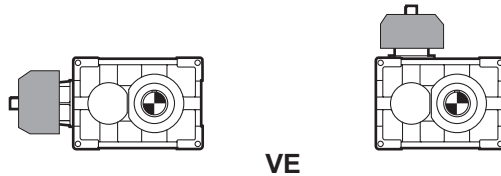

**[\*8] Antiretro**

**[\*8] Backstop**

**[\*8] Rücklaufperre**

Fare riferimento al capitolo sezione accessori G

Please refer to relevant chapter accessories section G

Siehe Kapitel "Zubehör" G

<b>Posizione antiretro a sinistra / Backstop on the left / Position der Rücklaufperre - links</b>					
↑	<b>ARSB</b>	Rotazione libera freccia bianca (B) <i>Free rotation - white arrow (B)</i> Freie Drehung – weißer Pfeil (B)	<b>A..O..DX</b> <b>AS..O..DX</b>	<b>C1..O..DX</b> <b>C2..O..DX</b>	<b>C1D..O..DX</b> <b>C2D..O..DX</b>
↑	<b>ARSN</b>	Rotazione libera freccia nera (N) <i>Free rotation - black arrow (N)</i> Freie Drehung – schwarzer Pfeil (N)			
<b>Posizione antiretro a destra / Backstop on the right / Position der Rücklaufperre – rechts</b>					
↑	<b>ARDB</b>	Rotazione libera freccia bianca (B) <i>Free rotation - white arrow (B)</i> Freie Drehung – weißer Pfeil (B)	<b>B..O..SX</b> <b>BS..O..SX</b>	<b>C1..O..SX</b> <b>C2..O..SX</b>	<b>C1S..O..DX</b> <b>C2S..O..DX</b>
↑	<b>ARDN</b>	Rotazione libera freccia nera (N) <i>Free rotation - black arrow (N)</i> Freie Drehung – schwarzer Pfeil (N)			

**[\*9] Materiale carcassa**

**[\*9] Casing material**

**[\*9] Gehäusematerial**

Materiale carcassa / Casing material / Gehäusematerial		<b>802</b>	<b>804</b>	<b>806</b>	<b>808</b>	<b>810</b>	<b>812</b>	<b>814</b>	<b>816</b>	<b>818</b>	<b>820</b>	<b>822</b>	<b>824</b>	<b>826</b>	<b>828</b>
Acciaio / Steel / Stahl	<b>A</b>														
Ghisa sferoidale / Spheroidal cast iron / Sphäroguss	<b>GS</b>														
Ghisa meccanica / Engineering cast iron / Maschinenguss	—														



**[\*10] Estremità uscita**

**[\*10] Output configuration**

**[\*10] Wellenende - Abtrieb**

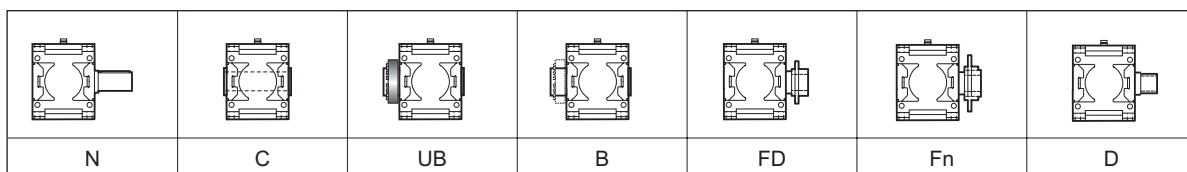

Altre opzioni uscita a richiesta

Other output options available on request

Weitere, auf Anfrage erhältliche Abtrieboptionen

<b>US</b>	Uscita speciale / Special output / Spezialabtrieb		Indicare le personalizzazioni richieste Specify required custom configurations Bitte spezielle Anforderungen angeben
-----------	---	--	--

Per ulteriori informazioni vedere la sezione Estremità

Please read Section "Input and Output Configurations" for more details.

Weitere Informationen finden Sie im Abschnitt "Wellenenden".

**[\*11] Posizioni di montaggio**

**[\*11] Mounting positions**

**[\*11] Einbaulagen**

Vedi pagina E14

Refer to page E14

Siehe betreffende Seiten E14

**[\*12] Opzioni disponibili**

**[\*12] Available options**

**[\*12] Verfügbare Optionen**

(vedi pag. G1)

(see page G1)

(Siehe Seite G1)

**[\*13] Tipo Entrata Supplementare**

**[\*13] Auxiliary drive type**

**[\*13] Zusätzlicher Antriebstyp**

O - Entrata Supplementare, con riduttore ortogonale

O - Auxiliary drive with helical bevel gear unit

O - Zusätzlicher Antrieb mit Kegelstirnrad-getriebe

**[\*14] Grandezza**

**[\*14] Size**

**[\*14] Baugröße**

Riduttore Principale  
Main gear unit  
Hauptgetriebe

	O71	O90	O112	O125	O140	O160	O180	O200
RXO2 802								
RXO2 804								
RXO2 806								
RXO2 808								
RXO2 810								
RXO2 812								
RXO2 814								
RXO2 816								
RXO2 818								
RXO2 820								
RXO2 822								
RXO2 824								
RXO2 826								
RXO2 828								

Riduttore Accoppiato  
Auxiliary drive gear unit  
Gepasstes Getriebe

**[\*15] Asse Riferimento**

**[\*15] Reference centreline**

**[\*15] Zusätzlicher Bezugsachse**

(2 - Asse di Riferimento dell'entrata supplementare.

(2 - Reference centreline of auxiliary drive unit.

(2 - Bezugsachse des zusätzlichen Antriebs.

(3 - Non Applicabile)

(3 - Not applicable)

(3 - nicht applizierbar)

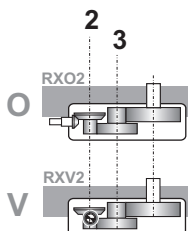

**[\*16] Posizione**

Con riferimento alla esecuzione grafica scelta la posizione della Entrata Supplementare può assumere le seguenti posizioni:

**SX** - Posizione a Sinistra.  
**DX** - Posizione a Destra.

La tabella seguente consente di definire la posizione della ES rispetto alla esecuzione grafica.

**[\*16] Position**

*Depending on selected shaft arrangement, the Auxiliary Drive unit can be installed on the left or on the right:*

**SX** - Left.  
**DX** - Right.

*Auxiliary drive positions according to shaft arrangement are reported in the following table.*

**[\*16] Position**

Unter Bezugnahme auf die gewählte grafische Ausführung kann der zusätzliche Antrieb in folgenden Positionen vorgesehen werden:

**SX** - links.  
**DX** - rechts.

Die folgende Tabelle gibt die Möglichkeit einer Definition des zusätzlichen Antriebs in Bezug auf die grafische Ausführung.

		Esecuzione Grafica / Shaft arrangement / Position des zusätzlichen Antriebs [4*]									
		A	AS	B	BS	C1	C2	C1D	C1S	C2D	C2S
Posizione Entrata Supplementare <i>Auxiliary Drive Position</i> Position des zusätzlichen Antriebs	SX										
	DX										

**[\*17] Rapporto di riduzione  $i_{es}$**

Vedi tabelle prestazioni

**[\*17] Reduction ratio  $i_{es}$**

See rating tables

**[\*17] Übersetzungsverhältnis  $i_{es}$**

Siehe Leistungstabelle

**[\*18] Estremità entrata**

**[\*18] Input configuration**

**[\*18] Wellenende - Antrieb**

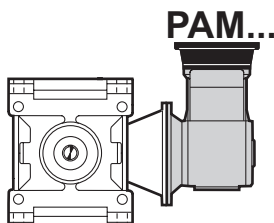

### 1.6 Lubrificazione

Gli oli disponibili appartengono generalmente a tre grandi famiglie:

- 1) Oli minerali
- 2) Oli sintetici Poli-Alfa-Olefine
- 3) Oli sintetici Poli-Glicole

La scelta più appropriata è generalmente legata alle condizioni di impiego, riduttori non particolarmente caricati e con un ciclo di impiego discontinuo, senza escursioni termiche importanti, possono certamente essere lubrificati con olio minerale.

Nei casi di impiego gravoso, quando i riduttori saranno prevedibilmente caricati molto ed in modo continuativo, con conseguente prevedibile innalzamento della temperatura, è bene utilizzare lubrificanti sintetici tipo polialfaolefine (PAO).

Gli oli di tipo poliglicole (PG) sono da utilizzare strettamente nel caso di applicazioni con forti strisciamenti fra i contatti, ad esempio nelle viti senza fine. Debbono essere impiegati con grande attenzione poiché non sono compatibili con gli altri oli e sono invece completamente miscibili con l'acqua. Questo fenomeno è particolarmente pericoloso poiché non si nota, ma deprime velocemente le caratteristiche lubrificanti dell'olio.

Oltre a questi già menzionati, ricordiamo che esistono gli oli per l'industria alimentare. Questi trovano specifico impiego nell'industria alimentare in quanto sono prodotti speciali non nocivi alla salute.

Vari produttori forniscono oli appartenenti a tutte le famiglie con caratteristiche molto simili. Più avanti proponiamo una tabella comparativa.

### 1.6 Lubrication

Available oils are typically grouped into three major classes:

- 1) Mineral oils
- 2) Poly-Alpha-Olefin synthetic oils
- 3) Polyglycol synthetic oils

Oil is normally selected in accordance with environmental and operating conditions. Mineral oil is the appropriate choice for moderate load, non-continuous duty applications free from temperature extremes.

In severe applications, where gear units are to operate under heavy loads in continuous duty and high temperatures are expected, synthetic Poly-Alpha-Olefin oils (PAO) are the preferred choice.

Polyglycol oils (PG) should only be used in applications involving high sliding friction, as is the case with worm shafts. These particular oils should be used with great care, as they are not compatible with other oils, but are totally mixable with water. The oil mixed with water cannot be told from uncontaminated oil, but will degrade very rapidly.

In addition to the oils mentioned above, there are food-grade oils. These are special oils harmless to human health for use in the food industry.

Oils with similar characteristics are available from a number of manufacturers. A comparative overview table is provided at the next pages.

### 1.6 Schmierung

Die verfügbaren Öle gehören im Allgemeinen drei großen Familien an:

- 1) Mineralöle
- 2) Polyalphaolefine-Synthetiköle
- 3) Polyglykol-Synthetiköle

Die angemessene Wahl ist im Allgemeinen an die Einsatzbedingungen gebunden. Getriebe, die keinen besonders schweren Belastungen ausgesetzt sind und einem unregelmäßigen Einsatzzyklus unterliegen, ohne starke thermische Ausschläge, können problemlos mit Mineralöl geschmiert werden.

Bei einem Einsatz unter harten Bedingungen, d.h. wenn die Getriebe stark und andauernd belastet werden, woraus sich ein sicherer Temperaturanstieg ergibt, sollten Synthetiköle, Typ Polyalphaolefine (PAO), verwendet werden.

Die Öle, Typ Polyglykole (PG), sind ausschließlich für einen Einsatz ausgelegt, bei denen es zu starken Reibungen zwischen den in Kontakt stehenden Elementen kommt, z.B. bei Schnecken. Bei ihrem Einsatz in besondere Aufmerksamkeit erforderlich, da sie nicht mit anderen Ölen kompatibel sind, sich jedoch vollständig mit Wasser vermischen lassen. Diese Tatsache erweist sich daher als besonders gefährlich, da sie sich nicht feststellen lässt, jedoch die Schmiereigenschaften des Öls bereits nach kurzer Zeit unterdrückt.

Über die bereits genannten Öle hinaus, gibt es auch Öle, die speziell für die Lebensmittelindustrie ausgelegt sind. Diese finden demzufolge dort ihren Einsatz, da es sich dabei um spezielle Produkte handelt, die für die Gesundheit unschädlich sind. Die den jeweiligen Familien angehörigen Ölsorten werden von verschiedenen Herstellern angeboten; sie weisen jeweils sehr ähnliche Eigenschaften auf. Auf der folgenden Seite finden Sie eine entsprechende Vergleichstabelle.

Input speed n <sub>1</sub> (min <sup>-1</sup> )	Absorbed power (IW)	Lubrication system	Viscosity ISO VG at 40° (cSt)	
			i ≤ 10	i > 10
2000 < n <sub>1</sub> ≤ 5000	P < 7.5	Forced or Oil splash	68	68
	7.5 ≤ P ≤ 22		68	150
	P > 22		150	220
1000 < n <sub>1</sub> ≤ 2000	P < 7.5	Forced or Oil splash	68	150
	7.5 ≤ P ≤ 37		150	220
	P > 37		220	320
300 < n <sub>1</sub> ≤ 1000	P < 15	Forced Oil splash	68	150
	15 ≤ P ≤ 55	Forced Oil splash	150	220
			220	320
P > 55	Forced Oil splash	220	320	
50 < n <sub>1</sub> ≤ 300	P < 22	Forced Oil splash	150	220
			220	320
	22 ≤ P ≤ 75	Forced Oil splash	220	320
			320	460
	P > 75	Forced Oil splash	320	460
			460	680

Tipo olio Oil type Öltyp	Temperatura olio Oil temperature Öltemperatur		
	65°C	80°C	90°C
Minerale Mineral Mineralöl	8000	3000	1000
Sintetica Synthetic Synthetiköl	20000	15000	9000

Frequenza cambi olio  
Oil change intervals [H]  
Oil change intervals [H]

Produttore Manufacturer Hersteller	Oli Minerali Mineral oils Mineralöle			Oli Sintetici Polialfaolefine (PAO) Poly-Alpha-Olefin synthetic oils (PAO) Polyalphaolefine- Synthetiköle (PAO)			Oli Sintetici Poliglicoli (PG) Polyglycol synthetic oils (PG) Polyglykol-Synthetiköle (PG)		
	ISO VG	ISO VG	ISO VG	ISO VG	ISO VG	ISO VG	ISO VG	ISO VG	ISO VG
	150	220	320	150	220	320	150	220	320
<b>AGIP</b>	Blasia 150	Blasia 220	Blasia 320	-	Blasia SX 220	Blasia SX 320	Blasia S 150	Blasia S 220	Blasia S 320
<b>ARAL</b>	Degol BG 150 Plus	Degol BG 220 Plus	Degol BG 320 Plus	Degol PAS 150	Degol PAS 220	Degol PAS 320	Degol GS 150	Degol GS 220	Degol GS 320
<b>BP</b>	Energol GR-XP 150	Energol GR-XP 220	Energol GR-XP 320	Energol EPX 150	Energol EPX 220	Energol EPX 320	Energol SG 150	Energol SG-XP 220	Energol SG-XP 320
<b>CASTROL</b>	Alpha SP 150	Alpha SP 220	Alpha SP 320	Alphasyn EP 150	Alphasyn EP 220	Alphasyn EP 320	Alphasyn PG 150	Alphasyn PG 220	Alphasyn PG 320
<b>CHEVRON</b>	Ultra Gear 150	Ultra Gear 220	Ultra Gear 320	Tegra Synthetic Gear 150	Tegra Synthetic Gear 220	Tegra Synthetic Gear 320	HiPerSYN 150	HiPerSYN 220	HiPerSYN 320
<b>ESSO</b>	Spartan EP 150	Spartan EP 220	Spartan EP 320	Spartan S EP 150	Spartan S EP 220	Spartan S EP 320	Glycolube 150	Glycolube 220	Glycolube 320
<b>KLÜBER</b>	Klüberoil GEM 1-150	Klüberoil GEM 1-220	Klüberoil GEM 1-320	Klübersynth EG 4-150	Klübersynth EG 4-220	Klübersynth EG 4-320	Klübersynth GH 6-150	Klübersynth GH 6-220	Klübersynth GH 6-320
<b>MOBIL</b>	Mobilgear XMP 150	Mobilgear XMP 220	Mobilgear XMP 320	Mobilgear SHC XMP 150	Mobilgear SHC XMP 220	Mobilgear SHC XMP 320	Glygoyle 22	Glygoyle 30	Glygoyle HE320
<b>MOLIKOTE</b>	L-0115	L-0122	L-0132	L-1115	L-1122	L-1132	-	-	-
<b>OPTIMOL</b>	Optigear BM 150	Optigear BM 220	Optigear BM 320	Optigear Synthetic A 150	Optigear Synthetic A 220	Optigear Synthetic A 320	Optiflex A 150	Optiflex A 220	Optiflex A 320
<b>Q8</b>	Goya 150	Goya 220	Goya 320	El Greco 150	El Greco 220	El Greco 320	Gade 150	Gade 220	Gade 320
<b>SHELL</b>	OMALA S2 G 150	OMALA S2 G 220	OMALA S2 G 320	Omala HD 150	Omala HD 220	Omala HD 320	OMALA S4 WE 150	OMALA S4 WE 220	OMALA S4 WE 320
<b>TEXACO</b>	Meropa 150	Meropa 220	Meropa 320	Pinnacle EP 150	Pinnacle EP 220	Pinnacle EP 320	-	Synlube CLP 220	Synlube CLP 320
<b>TOTAL</b>	Carter EP 150	Carter EP 220	Carter EP 320	Carter SH 150	Carter SH 220	Carter SH 320	Carter SY 150	Carter SY 220	Carter SY 320
<b>TRIBOL</b>	1100/150	1100/220	1100/320	1510/150	1510/220	1510/320	800/150	800/220	800/320

**Lubrificanti sintetici per uso alimentare / Food-grade synthetic lubricants / Schmiermittel Synthetik für Lebensmittelbereich**

<b>AGIP</b>				Rocol Foodlube Hi-Torque 150	—	Rocol Foodlube Hi-Torque 320			
<b>ESSO</b>				—	Gear Oil FM 220	—			
<b>KLÜBER</b>				Klüberoil 4 UH1 N 150	Klüberoil 4 UH1 N 220	Klüberoil 4 UH1 N 320			
<b>MOBIL</b>				DTE FM 150	DTE FM 220	DTE FM 320			
<b>SHELL</b>				Cassida Fluid GL 150	Cassida Fluid GL 220	Cassida Fluid GL 320			

Posizioni di montaggio

Mounting positions

Einbaulagen

Riduttore Primario  
Main Gear Unit  
Hauptgetriebe

Entrata Supplementare  
Auxiliary Drive  
Zusätzlicher Antrieb

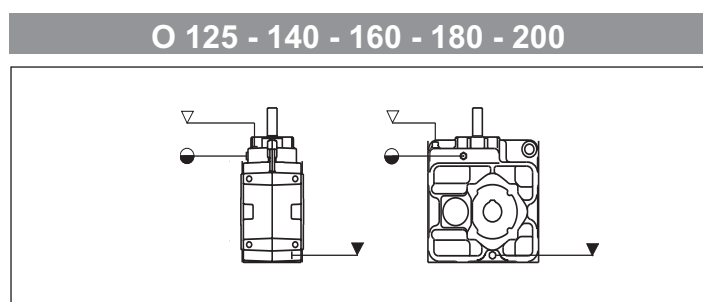
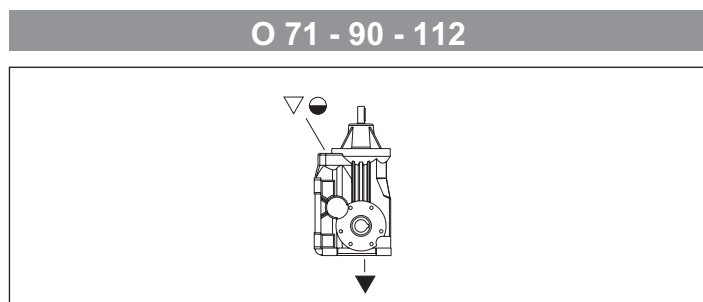
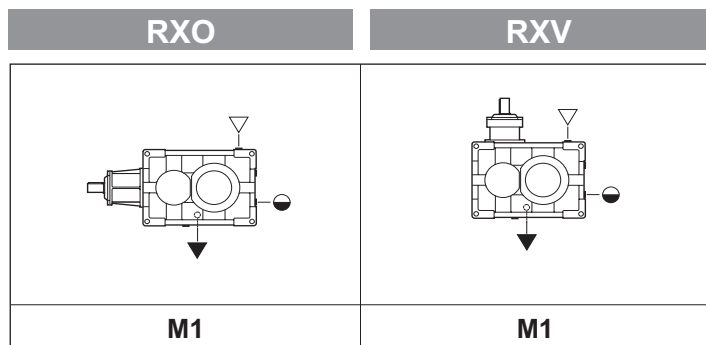

- ▽ Carico / Carico / Filler plug / Einfüllschraube
- ▼ Livello / Level plug / Schauglas
- Scarico / Drain plug / Ablassschraube

Riduttore Primario Main Gear Unit Hauptantrieb		Quantità di lubrificante Lubricant Quantity Schmiermittelmenge (l)	Entrata Supplementare Auxiliary Drive Zusätzlicher Antrieb	Quantità di lubrificante Lubricant Quantity Schmiermittelmenge (l)
<b>RXO2 RXV2</b>	802	3.3	O 71	1.95
	804	4.7		
	806	6.5		
	808	9	O 90	3.3
	810	13		
	812	18	O 112	6.7
	814	25		
	816	35	O 125	6
	818	49		
	820	69	O 140	10
	822	96		
	824	135	O 160	14
	826	189		
	828	—	O 180	22
		O 200	30	

Le quantità di olio sono approssimative; per una corretta lubrificazione occorre fare riferimento al livello segnato sul riduttore.

*Oil quantities listed in the table are approximate; to ensure correct lubrication, please refer to the level mark on the gear unit.*

Bei den Ölmengeangaben handelt es sich um approximative Werte; für den Erhalt einer korrekten Schmierung muss Bezug auf den am Getriebe gekennzeichneten Füllstand genommen werden.

**ATTENZIONE**

Eventuali forniture con predisposizioni tappi diverse da quella indicata in tabella, dovranno essere concordate.

**WARNING**

*Any plug arrangements other than that indicated in the table must be agreed upon.*

**ACHTUNG**

Eventuelle Lieferungen mit einer von den Tabellenangaben abweichenden Anordnung der Stopfen müssen zuvor abgestimmt werden.

**1.7 Verifica carichi radiali e assiali**

Qualora il collegamento tra riduttore e macchina motrice o operatrice sia effettuato con mezzi che generano carichi radiali sull'estremità d'albero veloce o lento, occorre fare le seguenti verifiche.

**Calcolo  $Fr_2'$  e  $Fr_1'$**

I carichi massimi  $Fr_1$  e  $Fr_2$  sono calcolati con  $F_s=1$  ed a una distanza dalla battuta dell'albero di 0.5 S se albero veloce o 0.5 R se albero lento.

Tali valori sono riportati nelle tabelle delle prestazioni.

Per distanze variabili tra 0 e una distanza "X" bisogna utilizzare le tabelle seguenti:

$Fr_2$  con coefficiente A.

$Fr_2$  con coefficiente C nel caso di flange FD.

$Fr_1$  con coefficiente B.

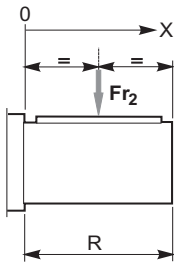

$$Fr_2' = Fr_2 \cdot \left( \frac{A}{A + X - \frac{R}{2}} \right)$$

$$Fr_2' = Fr_2 \cdot C$$

solo per esecuzione FD  
only for FD, configuration  
Nur für Ausführungen FD

**1.7 Overhung and thrust load verification**

When a gear unit is connected to prime mover or driven machine using overhung drive members that place a radial load on input or output shaft end, check the following loads.

**$Fr_2'$  e  $Fr_1'$  calculation**

Load capacity ratings  $Fr_1$  and  $Fr_2$  consider a service factor  $F_s=1$  and load location at a distance from shaft shoulder of 0.5 S for input shafts or 0.5 R for output shafts.

These values are reported in the rating tables.

Where load is applied at a distance from shoulder between 0 and an "X" distance, refer to the following tables:

$Fr_2$  with load location factor A.

$Fr_2$  with load location factor C if an FD flange is used.

$Fr_1$  with load location factor B.

**1.7 Überprüfung der Radial- und Axialkräfte**

Erfolgt die Verbindung zwischen Getriebe und Kraft- oder Arbeitsmaschine mit Vorrichtungen, die Radialkräfte auf das Ende der Antriebs- oder Abtriebswelle ausüben, sind folgende Überprüfungen erforderlich.

**Berechnung von  $Fr_2'$  e  $Fr_1'$**

Die maximalen Belastungskräfte  $Fr_1$  und  $Fr_2$  werden mit  $F_s=1$  und auf einem Abstand vom Wellenansatz von 0.5 S im Fall der Antriebswelle oder 0.5 R im Fall der Abtriebswelle berechnet.

Diese Werte werden in den Leistungstabellen angegeben.

Bei zwischen 0 und einer Distanz "X" variierenden Abständen müssen folgende Tabellen verwendet werden:

$Fr_2$  mit Koeffizient A.

$Fr_2$  mit Koeffizient C bei FD-Flanschen.

$Fr_1$  mit Koeffizient B.

$Fr_2'$ [N]	Carico radiale ammissibile su albero uscita alla distanza X	Permissible output shaft OHL at distance X	An Abtriebswelle auf Distanz X zulässige Radialkraft
$Fr_2$ [N]	Carico radiale ammissibile su albero uscita indicato a catalogo	Output shaft OHL capacity as per catalogue rating	An Abtriebswelle gemäß Katalogangaben zulässige Radialkraft
X [mm]	Distanza dalla battuta dell'albero	Distance from shaft shoulder	Distanz vom Wellenansatz
R [mm]	Sporgenza dell'albero uscita	Output shaft projection	Überstand der Abtriebswelle
A	Coefficiente da tabella	Load location factor from table	Koeffizient aus Tabelle

Coefficienti correttivi del carico radiale di catalogo in uscita  $Fr_2$  in funzione della distanza dalla battuta

Load location factors to adjust output OHL capacity rating  $Fr_2$  based on distance from shoulder

Korrekturkoeffizient der Radialkraft am Abtrieb  $Fr_2$  gemäß Katalog in Abhängigkeit des Ansatzabstands

	RXP															
	802	804	806	808	810	812	814	816	818	820	822	824	826	828	830	832
<b>A</b>	99	109	124	137	156	175	200	225	236	261	294	331	385	405	447	507
<b>C</b>	1.32	1.35	1.39	1.46	1.49	1.43	1.32	1.32	1.33	1.35	1.32					

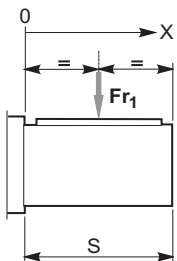

$$Fr_1' = Fr_1 \cdot \left( \frac{B}{B + X - \frac{S}{2}} \right)$$

$Fr_1'$ [N]	Carico radiale ammissibile su albero entrata alla distanza X	Permissible input shaft OHL at distance X	An Abtriebswelle auf Distanz X zulässige Radialkraft
$Fr_1$ [N]	Carico radiale ammissibile su albero entrata indicato a catalogo	Input shaft OHL capacity as per catalogue rating	An Abtriebswelle gemäß Katalogangaben zulässige Radialkraft
X [mm]	Distanza dalla battuta dell'albero	Distance from shaft shoulder	Distanz vom Wellenansatz
S [mm]	Sporgenza dell'albero entrata	Input shaft projection	Überstand der Abtriebswelle
B	Coefficiente da tabella	Load location factor from table	Koeffizient aus Tabelle

Coefficienti correttivi del carico radiale di catalogo in entrata  $Fr_1$  in funzione della distanza dalla battuta

Load location factors to adjust input OHL capacity rating  $Fr_1$  based on distance from shoulder

Korrekturkoeffizient der Radialkraft am Antrieb  $Fr_1$  gemäß Katalog in Abhängigkeit des Ansatzabstands

	Size	802	804	806	808	810	812	814	816	818	820	822	824	826	828	830	832
	<b>B</b>	RXP2	68	75	85	95	105	120	136	152	172	190	210	240	260	300	
	RXP3	87	98	110	121	142	155	173	195	212	240	271	305	344	387	435	484

**Calcolo Fr**

Per calcolare il carico Fr agente sull'albero lento diamo formule approssimate per alcune trasmissioni più comuni, per la determinazione del carico radiale su albero veloce o lento.

$$Fr = k \cdot \frac{T}{d}$$

**Fr** [N] Carico radiale approssimato  
Approximate overhung load  
Approx. Wert - Radialkraft

**d** [mm] Diametro pulegge, ruote  
Pulley diameter, wheels  
Durchmesser Räder,  
Riemenscheiben

**k** Fattore di collegamento  
Connection factor  
Anschlusswert

**T** [Nm] Momento torcente  
Torque  
Drehmoment

k =	7000	5000	3000	2120	2000
Trasmissioni Drive member Antriebe	Ruote di frizione (gomma su metallo) Friction wheel drive (rubber on metal) Kupplungsräder (Gummi auf Metall)	Cinghie trapezoidali V belt drives Keilriemen	Cinghie dentate Toothed belts Zahnriemen	Ingranaggi cilindrici Spur gears Zylinderzahnäder	Catene Chain drives Ketten

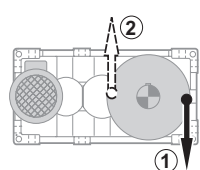

Nel caso di sollevamento con tamburo con tiro verso il basso è preferibile che la fune si avvolga dalla parte opposta al motore (1).  
Nel caso più gravoso del precedente, con tiro verso l'alto, viceversa è preferibile che la fune si avvolga dal lato motore (2).

*In lifting applications using winch drums in a downward pull direction, it is best for the rope to wrap on the side opposite to the motor (1).  
In the more severe case of upward pull direction, the rope should wrap on motor side (2).*

Beim Hebeverfahren mit einer Trommel mit Zugkraft nach unten sollte das Seil auf der dem Motor (1) entgegen gesetzten Seite aufgerollt werden.  
Im Fall eines härteren Einsatzes als den zuvor genannten, mit Zugkraft nach oben, sollte das Seil dagegen an der Motorseite (2) aufgewickelt werden.

**Verifiche**

**Caso A)**  
Per carichi radiali minori di 0.25 Fr<sub>1'</sub> o Fr<sub>2'</sub> è necessario verificare soltanto che contemporaneamente al carico radiale sia presente un carico assiale non superiore a 0.2 volte Fr<sub>1'</sub> o Fr<sub>2'</sub>;

**Caso B)**  
Per carichi radiali maggiori di 0.25 Fr<sub>1'</sub> o Fr<sub>2'</sub>;  
1) Calcolo abbreviato: Fr (input) < Fr<sub>1'</sub> e Fr (output) < Fr<sub>2'</sub> e che contemporaneamente al carico radiale sia presente un carico assiale non superiore a 0.2 volte Fr<sub>1'</sub> o Fr<sub>2'</sub>;

2) Calcolo completo per il quale occorre fornire i seguenti dati:  
- momento torcente applicato o potenza applicata  
- n<sub>1</sub> e n<sub>2</sub> (giri al minuto dell'albero veloce e dell'albero lento)  
- carico radiale Fr (direzione, intensità, verso)

**Verification**

**Case A)**  
For overhung loads lower than 0.25 Fr<sub>1'</sub> or Fr<sub>2'</sub>, ensure that the thrust load applied simultaneously with OHL is not greater than 0.2 times Fr<sub>1'</sub> or Fr<sub>2'</sub>;

**Case B)**  
For overhung loads greater than 0.25 Fr<sub>1'</sub> or Fr<sub>2'</sub>;  
1) Quick calculation method: Fr (input) < Fr<sub>1'</sub> and Fr (output) < Fr<sub>2'</sub> and thrust load applied simultaneously with OHL not greater than 0.2 times Fr<sub>1'</sub> or Fr<sub>2'</sub>;

2) For the standard calculation method, the following information is required:  
- applied torque or power  
- n<sub>1</sub> and n<sub>2</sub> (input and output shaft rpm)  
- overhung load Fr (orientation, amount of loading, direction)

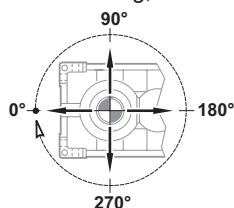

-senso di rotazione dell'albero

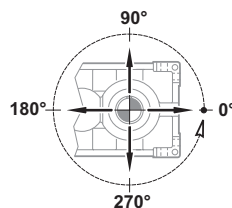

-direction of rotation of shaft

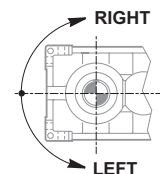

- grandezza e tipo del riduttore scelto  
- tipo olio impiegato e sua viscosità

- size and type of selected gear unit  
- oil type and viscosity

- esecuzione grafica assi:

- shaft arrangement:

- carico assiale presente Fa  
Consultare il supporto Tecnico per la verifica.

- actual thrust load Fa  
Please contact our Engineering for a verification.

**Berechnung der Fr**

Für die Berechnung der an der Abtriebswelle wirkenden Belastungen Fr geben wir approximative Formeln an, die für einige der allgemeinen Antriebsformen zum Bestimmen der auf die An- oder Abtriebswelle einwirkenden Radialkraft verwendet werden können.

**Überprüfungen**

**Fall A)**  
Bei Radialkräften unter 0.25 Fr<sub>1'</sub> oder Fr<sub>2'</sub> muss nur überprüft werden, dass gleichzeitig mit der Belastung durch die Radialkraft auch eine Axialkraft von nicht mehr als 0.2 Mal Fr<sub>1'</sub> oder Fr<sub>2'</sub> vorliegt.

**Fall B)**  
Bei Radialkräften über 0.25 Fr<sub>1'</sub> oder Fr<sub>2'</sub>;  
1) Verkürzte Berechnungsgleichung: Fr (input) < Fr<sub>1'</sub> und Fr (output) < Fr<sub>2'</sub> und dass gleichzeitig mit der Belastung durch die Radialkraft auch eine Axialkraft von nicht mehr als 0.2 Mal Fr<sub>1'</sub> oder Fr<sub>2'</sub> vorliegt.

2) Vollständige Berechnungsgleichung für die folgende Daten erforderlich sind:  
- appliziertes Drehmoment oder applizierte Leistung  
- n<sub>1</sub> und n<sub>2</sub> (Drehungen/Minute der Antriebs- und Abtriebswelle)  
- Radialkraft Fr (Richtung, Intensität, Seite)

- Drehrichtung der Welle

- Baugröße und Typ des gewählten Getriebes  
- verwendeter Öltyp und dessen Viskositätsgrad  
- grafische Achsenausführung  
- vorliegende Axialkraft Fa  
Für eine Überprüfung die Technischen Unterlagen konsultieren.



1.8 Prestazioni riduttore

1.8 Gear unit ratings

1.8 Getriebeleistungen

802	Riduttore primario / Main gear unit / Hauptantrieb					Entrata Supplementare / Auxiliary Drive / Zusätzlicher Antrie			
	ir	n <sub>2</sub> min <sup>-1</sup>	P <sub>N</sub> kW	T <sub>N</sub> kNm	Fr <sub>2</sub> /Fr <sub>1</sub> kN	ir <sub>es</sub>	n <sub>3</sub> min <sup>-1</sup>	P <sub>2</sub> kW	K2
n <sub>1</sub> min <sup>-1</sup>  1450	28.5	51	18.8	3.3	11/1.9	502.1	2.9	1.21	0.064
	30.6	47	17.6	3.3	11/2.0	539.3	2.7	1.13	0.064
	32.9	44	16.4	3.3	11/2.0	505.8	2.9	1.21	0.074
	38.6	38	14.1	3.3	11/2.1	488.9	3.0	1.26	0.089
	46.0	32	12.0	3.4	11/2.1	515.9	2.8	1.21	0.101
	49.6	29	11.1	3.4	11/2.1	505.8	2.9	1.24	0.111
	58.1	25	9.6	3.4	11/2.1	488.9	3.0	1.29	0.135
	63.3	23	8.8	3.4	11/2.2	532.4	2.7	1.19	0.135
Potenza termica / Thermal power / Thermische Leistung (senza raffreddamento / Without cooling / ohne Kühlung) 24									

804	Riduttore primario / Main gear unit / Hauptantrieb					Entrata Supplementare / Auxiliary Drive / Zusätzlicher Antrie			
	ir	n <sub>2</sub> min <sup>-1</sup>	P <sub>N</sub> kW	T <sub>N</sub> kNm	Fr <sub>2</sub> /Fr <sub>1</sub> kN	ir <sub>es</sub>	n <sub>3</sub> min <sup>-1</sup>	P <sub>2</sub> kW	K2
n <sub>1</sub> min <sup>-1</sup>  1450	30.6	47	25	4.7	15/2.25	538.6	2.7	1.62	0.064
	32.9	44	23	4.7	15/2.25	505.1	2.9	1.73	0.074
	38.5	38	20	4.8	15/2.25	487.9	3.0	1.80	0.089
	41.9	35	19	4.8	15/2.35	531.1	2.7	1.66	0.089
	45.9	32	17	4.8	15/2.35	514.6	2.8	1.72	0.101
	49.5	29	16	4.8	15/2.35	505.1	2.9	1.76	0.111
	58.0	25	14	4.9	15/2.35	487.9	3.0	1.84	0.135
	63.1	23	13	4.9	15/2.5	531.1	2.7	1.70	0.135
Potenza termica / Thermal power / Thermische Leistung (senza raffreddamento / Without cooling / ohne Kühlung) 30									

806	Riduttore primario / Main gear unit / Hauptantrieb					Entrata Supplementare / Auxiliary Drive / Zusätzlicher Antrie			
	ir	n <sub>2</sub> min <sup>-1</sup>	P <sub>N</sub> kW	T <sub>N</sub> kNm	Fr <sub>2</sub> /Fr <sub>1</sub> kN	ir <sub>es</sub>	n <sub>3</sub> min <sup>-1</sup>	P <sub>2</sub> kW	K2
n <sub>1</sub> min <sup>-1</sup>  1450	28.0	52	41	7.1	19/3.25	489.1	3.0	2.63	0.064
	30.0	48	39	7.1	19/3.4	523.5	2.8	2.47	0.064
	34.6	42	34	7.2	19/3.4	528.7	2.7	2.46	0.073
	37.4	39	31	7.2	19/3.4	502.7	2.9	2.60	0.083
	44.1	33	27	7.2	19/3.6	525.3	2.8	2.51	0.094
	52.1	28	23	7.3	19/3.6	528.7	2.7	2.51	0.110
	56.3	26	21	7.3	19/3.6	502.7	2.9	2.65	0.125
	66.3	22	18	7.4	19/3.8	525.3	2.8	2.56	0.141
Potenza termica / Thermal power / Thermische Leistung (senza raffreddamento / Without cooling / ohne Kühlung) 40									

808	Riduttore primario / Main gear unit / Hauptantrieb					Entrata Supplementare / Auxiliary Drive / Zusätzlicher Antrie			
	ir	n <sub>2</sub> min <sup>-1</sup>	P <sub>N</sub> kW	T <sub>N</sub> kNm	Fr <sub>2</sub> /Fr <sub>1</sub> kN	ir <sub>es</sub>	n <sub>3</sub> min <sup>-1</sup>	P <sub>2</sub> kW	K2
n <sub>1</sub> min <sup>-1</sup>  1450	27.1	54	61	10.1	34/6.1	472.6	3.1	3.88	0.064
	29.0	50	57	10.1	34/6.1	506.4	2.9	3.64	0.064
	33.5	43	50	10.2	34/6.3	512.3	2.8	3.62	0.073
	39.3	37	43	10.3	34/6.6	468.5	3.1	3.99	0.094
	46.8	31	36	10.4	34/6.6	498.2	2.9	3.79	0.105
	50.5	29	34	10.4	34/6.6	512.3	2.8	3.70	0.110
	59.2	25	29	10.5	34/6.6	468.5	3.1	4.08	0.141
	64.4	23	27	10.5	34/6.9	510.2	2.8	3.76	0.141
Potenza termica / Thermal power / Thermische Leistung (senza raffreddamento / Without cooling / ohne Kühlung) 52									



1.8 Prestazioni riduttore

1.8 Gear unit ratings

1.8 Getriebeleistungen

810	Riduttore primario / Main gear unit / Hauptantrieb					Entrata Supplementare / Auxiliary Drive / Zusätzlicher Antrie			
	ir	n <sub>2</sub> min <sup>-1</sup>	P <sub>N</sub> kW	T <sub>N</sub> kNm	Fr <sub>2</sub> /Fr <sub>1</sub> kN	ir <sub>es</sub>	n <sub>3</sub> min <sup>-1</sup>	P <sub>2</sub> kW	K2
n <sub>1</sub> min <sup>-1</sup>  1450	27.6	53	82	13.8	44/7.0	492.5	2.9	5.11	0.062
	29.5	49	77	13.9	44/7.0	527.7	2.7	4.78	0.062
	34.1	42	67	14.0	44/7.2	539.8	2.7	4.71	0.071
	40.0	36	57	14.1	44/7.5	486.8	3.0	5.27	0.092
	43.6	33	53	14.2	44/7.5	530.1	2.7	4.86	0.092
	51.4	28	45	14.3	44/7.5	539.8	2.7	4.81	0.106
	60.2	24	39	14.4	44/7.5	486.8	3.0	5.37	0.138
	65.6	22	36	14.4	44/7.7	530.1	2.7	4.96	0.138
Potenza termica / Thermal power / Thermische Leistung (senza raffreddamento / Without cooling / ohne Kühlung) 65									

812	Riduttore primario / Main gear unit / Hauptantrieb					Entrata Supplementare / Auxiliary Drive / Zusätzlicher Antrie			
	ir	n <sub>2</sub> min <sup>-1</sup>	P <sub>N</sub> kW	T <sub>N</sub> kNm	Fr <sub>2</sub> /Fr <sub>1</sub> kN	ir <sub>es</sub>	n <sub>3</sub> min <sup>-1</sup>	P <sub>2</sub> kW	K2
n <sub>1</sub> min <sup>-1</sup>  1450	28.0	52	119	20.5	49/9.5	501.1	2.9	7.46	0.062
	30.1	48	112	20.6	49/9.7	538.2	2.7	6.97	0.062
	35.0	41	97	20.8	49/9.7	475.6	3.0	7.94	0.082
	41.4	35	82	20.9	49/10	503.4	2.9	7.57	0.092
	45.3	32	76	21.0	49/10	479.7	3.0	7.98	0.105
	52.7	28	66	21.2	49/10	475.6	3.0	8.11	0.124
	57.2	25	61	21.3	49/10	515.8	2.8	7.51	0.124
	62.3	23	56	21.4	49/10.4	503.4	2.9	7.72	0.138
Potenza termica / Thermal power / Thermische Leistung (senza raffreddamento / Without cooling / ohne Kühlung) 82									

814	Riduttore primario / Main gear unit / Hauptantrieb					Entrata Supplementare / Auxiliary Drive / Zusätzlicher Antrie			
	ir	n <sub>2</sub> min <sup>-1</sup>	P <sub>N</sub> kW	T <sub>N</sub> kNm	Fr <sub>2</sub> /Fr <sub>1</sub> kN	ir <sub>es</sub>	n <sub>3</sub> min <sup>-1</sup>	P <sub>2</sub> kW	K2
n <sub>1</sub> min <sup>-1</sup>  1450	28.5	51	161	28.0	58/11.7	542.1	2.7	8.71	0.054
	30.6	47	150	28.1	58/12.0	488.6	3.0	9.70	0.065
	32.9	44	140	28.3	58/12.0	526.3	2.8	9.04	0.065
	38.6	38	120	28.5	58/12.2	488.9	3.0	9.80	0.082
	46.0	32	102	28.7	58/12.2	542.6	2.7	8.91	0.088
	49.6	29	95	28.8	58/12.2	526.3	2.8	9.22	0.097
	58.1	25	82	29.1	58/12.2	488.9	3.0	10.01	0.123
	63.3	23	75	29.2	58/12.4	532.4	2.7	9.23	0.123
Potenza termica / Thermal power / Thermische Leistung (senza raffreddamento / Without cooling / ohne Kühlung) 102									

816	Riduttore primario / Main gear unit / Hauptantrieb					Entrata Supplementare / Auxiliary Drive / Zusätzlicher Antrie			
	ir	n <sub>2</sub> min <sup>-1</sup>	P <sub>N</sub> kW	T <sub>N</sub> kNm	Fr <sub>2</sub> /Fr <sub>1</sub> kN	ir <sub>es</sub>	n <sub>3</sub> min <sup>-1</sup>	P <sub>2</sub> kW	K2
n <sub>1</sub> min <sup>-1</sup>  1450	26.6	55	246	40.0	70/14.8	505.7	2.9	13.33	0.054
	30.6	47	215	40.3	70/15.1	488.0	3.0	13.91	0.065
	32.9	44	201	40.5	70/15.1	525.5	2.8	12.96	0.065
	38.5	38	173	40.8	70/15.5	487.9	3.0	14.08	0.082
	45.9	32	146	41.2	70/15.5	541.2	2.7	12.80	0.088
	49.5	29	136	41.3	70/15.5	525.5	2.8	13.23	0.097
	58.0	25	117	41.6	70/15.5	487.9	3.0	14.37	0.123
	63.1	23	108	41.8	70/15.7	531.1	2.7	13.25	0.123
Potenza termica / Thermal power / Thermische Leistung (senza raffreddamento / Without cooling / ohne Kühlung) 127									

## 1.8 Prestazioni riduttore

## 1.8 Gear unit ratings

## 1.8 Getriebeleistungen

818	Riduttore primario / Main gear unit / Hauptantrieb					Entrata Supplementare / Auxiliary Drive / Zusätzlicher Antrie			
	ir	n <sub>2</sub> min <sup>-1</sup>	P <sub>N</sub> kW	T <sub>N</sub> kNm	Fr <sub>2</sub> /Fr <sub>1</sub> kN	ir <sub>es</sub>	n <sub>3</sub> min <sup>-1</sup>	P <sub>2</sub> kW	K2
n <sub>1</sub> min <sup>-1</sup>  1450	28.0	52	345	59.2	80/17.1	523.8	2.8	19.03	0.055
	30.0	48	323	59.4	80/17.6	470.2	3.1	21.28	0.066
	34.6	42	282	59.9	80/17.6	543.0	2.7	18.56	0.066
	37.4	39	262	60.1	80/17.6	464.1	3.1	21.80	0.083
	44.1	33	224	60.6	80/18.0	510.7	2.8	19.97	0.089
	52.1	28	191	61.1	80/18.0	543.0	2.7	18.94	0.099
	56.3	26	178	61.3	80/18.0	464.1	3.1	22.25	0.125
	66.3	22	152	61.8	80/18.9	510.7	2.8	20.38	0.134
Potenza termica / Thermal power / Thermische Leistung (senza raffreddamento / Without cooling / ohne Kühlung) 165									

820	Riduttore primario / Main gear unit / Hauptantrieb					Entrata Supplementare / Auxiliary Drive / Zusätzlicher Antrie			
	ir	n <sub>2</sub> min <sup>-1</sup>	P <sub>N</sub> kW	T <sub>N</sub> kNm	Fr <sub>2</sub> /Fr <sub>1</sub> kN	ir <sub>es</sub>	n <sub>3</sub> min <sup>-1</sup>	P <sub>2</sub> kW	K2
n <sub>1</sub> min <sup>-1</sup>  1450	27.1	54	489	81.1	142/19.8	506.2	2.9	26.98	0.055
	31.1	47	428	81.7	142/20.2	488.5	3.0	28.16	0.066
	36.3	40	370	82.3	142/20.2	525.0	2.8	26.40	0.071
	39.3	37	343	82.7	142/20.7	488.0	3.0	28.51	0.083
	46.8	31	290	83.4	142/20.7	542.8	2.7	25.86	0.089
	54.5	27	251	84.0	142/20.7	525.0	2.8	26.94	0.107
	59.2	25	233	84.4	142/20.7	488.0	3.0	29.10	0.125
	64.4	23	215	84.7	142/21.6	531.4	2.7	26.84	0.125
Potenza termica / Thermal power / Thermische Leistung (senza raffreddamento / Without cooling / ohne Kühlung) 205									

822	Riduttore primario / Main gear unit / Hauptantrieb					Entrata Supplementare / Auxiliary Drive / Zusätzlicher Antrie			
	ir	n <sub>2</sub> min <sup>-1</sup>	P <sub>N</sub> kW	T <sub>N</sub> kNm	Fr <sub>2</sub> /Fr <sub>1</sub> kN	ir <sub>es</sub>	n <sub>3</sub> min <sup>-1</sup>	P <sub>2</sub> kW	K2
n <sub>1</sub> min <sup>-1</sup>  1450	27.6	53	657	111.0	178/27.9	524.4	2.8	35.62	0.054
	29.5	49	615	111.3	178/27.9	471.5	3.1	39.75	0.065
	34.1	42	536	112.2	178/28.8	545.4	2.7	34.61	0.065
	40.0	36	461	113.0	178/29.7	506.6	2.9	37.56	0.082
	43.6	33	425	113.5	178/29.7	513.9	2.8	37.19	0.088
	52.5	28	356	114.6	178/29.7	540.7	2.7	35.67	0.100
	60.2	24	313	115.4	178/29.7	506.6	2.9	38.33	0.123
	65.6	22	288	115.9	178/30.6	513.9	2.8	37.95	0.132
Potenza termica / Thermal power / Thermische Leistung (senza raffreddamento / Without cooling / ohne Kühlung) 248									

824	Riduttore primario / Main gear unit / Hauptantrieb					Entrata Supplementare / Auxiliary Drive / Zusätzlicher Antrie			
	ir	n <sub>2</sub> min <sup>-1</sup>	P <sub>N</sub> kW	T <sub>N</sub> kNm	Fr <sub>2</sub> /Fr <sub>1</sub> kN	ir <sub>es</sub>	n <sub>3</sub> min <sup>-1</sup>	P <sub>2</sub> kW	K2
n <sub>1</sub> min <sup>-1</sup>  1450	28.6	51	949	166.2	200/36	504.6	2.9	55.44	0.058
	30.7	47	887	166.8	200/36.9	542.0	2.7	51.81	0.058
	35.7	41	768	168.0	200/36.9	494.5	2.9	57.19	0.075
	38.7	37	711	168.7	200/37.8	498.5	2.9	56.97	0.080
	46.1	31	602	170.2	200/37.8	517.2	2.8	55.40	0.092
	52.7	28	530	171.3	200/37.8	494.5	2.9	58.32	0.110
	57.2	25	491	172.0	200/37.8	498.5	2.9	58.08	0.118
	68.1	21	415	173.6	200/39.6	517.2	2.8	56.50	0.136
Potenza termica / Thermal power / Thermische Leistung (senza raffreddamento / Without cooling / ohne Kühlung) 306									

## 1.8 Prestazioni riduttore

## 1.8 Gear unit ratings

## 1.8 Getriebeleistungen

826	Riduttore primario / Main gear unit / Hauptantrieb					Entrata Supplementare / Auxiliary Drive / Zusätzlicher Antrie			
	ir	n <sub>2</sub> min <sup>-1</sup>	P <sub>N</sub> kW	T <sub>N</sub> kNm	Fr <sub>2</sub> /Fr <sub>1</sub> kN	ir <sub>es</sub>	n <sub>3</sub> min <sup>-1</sup>	P <sub>2</sub> kW	K2
1450	28.6	51	1288	226.1	235/42.3	538.6	2.7	70.66	0.055
	30.7	47	1204	226.9	235/44.1	489.9	3.0	77.96	0.065
	33.1	44	1122	227.8	235/44.1	527.7	2.7	72.67	0.065
	38.8	37	965	229.6	235/45.9	496.9	2.9	77.79	0.081
	42.3	34	890	230.6	235/45.9	504.5	2.9	76.93	0.086
	50.9	28	746	232.7	235/45.9	534.3	2.7	73.31	0.098
	57.2	25	667	234.1	235/45.9	496.9	2.9	79.31	0.119
	62.3	23	615	235.1	235/47.7	504.5	2.9	78.44	0.128
Potenza termica / Thermal power / Thermische Leistung (senza raffreddamento / Without cooling / ohne Kühlung) 368									

828	Riduttore primario / Main gear unit / Hauptantrieb					Entrata Supplementare / Auxiliary Drive / Zusätzlicher Antrie			
	ir	n <sub>2</sub> min <sup>-1</sup>	P <sub>N</sub> kW	T <sub>N</sub> kNm	Fr <sub>2</sub> /Fr <sub>1</sub> kN	ir <sub>es</sub>	n <sub>3</sub> min <sup>-1</sup>	P <sub>2</sub> kW	K2
1450	27.1	53	1926	320.3	272/53.1	502.4	2.9	107.32	0.056
	31.2	46	1687	322.5	272/54.9	489.3	3.0	110.95	0.066
	33.6	43	1572	323.7	272/54.9	526.8	2.8	103.42	0.066
	39.3	37	1353	326.3	272/56.7	495.8	2.9	110.78	0.082
	46.8	31	1146	329.2	272/56.7	484.2	3.0	114.44	0.100
	49.2	29	1093	330.0	272/56.7	526.8	2.8	105.44	0.096
	57.6	25	941	332.6	272/56.7	495.8	2.9	112.92	0.120
	62.8	23	868	334.0	272/58.5	503.4	2.9	111.69	0.129
Potenza termica / Thermal power / Thermische Leistung (senza raffreddamento / Without cooling / ohne Kühlung) 445									

1.9 Momenti d'inerzia

1.9 Moments of inertia

1.9 Trägheitsmomente

		RX02 - RXV2													
		802	804	806	808	810	812	814	816	818	820	822	824	826	828
ir	-	19.4	19.4	20.5	19.7	20.1	19.1	19.4	19.4	19.4	19.7	20.1	19.4	19.5	19.8
J1	kgm <sup>2</sup>	0.0016	0.0029	0.0050	0.0083	0.0150	0.0271	0.0479	0.0850	0.1512	0.2690	0.4785	0.8503	1.5118	2.6814
ir	-	21.9	21.9	21.8	22.3	22.7	21.5	21.9	21.9	21.8	22.3	22.7	21.9	22.0	22.3
J1	kgm <sup>2</sup>	0.0014	0.0027	0.0046	0.0078	0.0141	0.0252	0.0447	0.0793	0.1411	0.2510	0.4465	0.7936	1.4111	2.5028
ir	-	24.9	24.9	24.6	23.7	24.2	24.5	24.9	24.9	24.6	23.7	25.8	24.9	25.0	25.4
J1	kgm <sup>2</sup>	0.0013	0.0024	0.0042	0.0073	0.0132	0.0235	0.0417	0.0740	0.1317	0.2342	0.4167	0.7407	1.3170	2.3360
ir	-	28.5	30.6	28.0	27.1	27.6	28.0	28.5	26.6	28.0	27.1	27.6	28.6	28.6	27.1
J1	kgm <sup>2</sup>	0.0012	0.0022	0.0039	0.0069	0.0123	0.0219	0.0389	0.0691	0.1229	0.2186	0.3888	0.6913	1.2293	2.1804
ir	-	30.6	32.9	30.0	29.0	29.5	30.1	30.6	30.6	30.0	31.1	29.5	30.7	30.7	31.2
J1	kgm <sup>2</sup>	0.0011	0.0020	0.0036	0.0065	0.0115	0.0204	0.0363	0.0645	0.1147	0.2040	0.3628	0.6452	1.1474	2.0351
ir	-	33.0	38.5	34.6	33.5	34.1	35.0	33.0	32.9	34.6	36.3	34.1	35.7	33.1	33.6
J1	kgm <sup>2</sup>	0.0011	0.0019	0.0034	0.0060	0.0107	0.0190	0.0339	0.0602	0.1071	0.1904	0.3386	0.6022	1.0709	1.8995
ir	-	38.6	41.9	37.4	39.3	40.0	41.4	38.6	38.5	37.4	39.3	40.0	38.7	38.8	39.3
J1	kgm <sup>2</sup>	0.0010	0.0018	0.0032	0.0056	0.0100	0.0178	0.0316	0.0562	0.1000	0.1777	0.3161	0.5621	0.9995	1.7728
ir	-	46.0	45.9	44.1	46.8	43.6	45.3	46.0	45.9	44.1	46.8	43.6	46.1	42.3	46.8
J1	kgm <sup>2</sup>	0.0009	0.0017	0.0030	0.0053	0.0093	0.0166	0.0295	0.0525	0.0933	0.1659	0.2950	0.5246	0.9329	1.6547
ir	-	49.6	49.5	52.1	50.5	51.4	52.7	49.6	49.5	52.1	54.5	52.5	52.7	50.9	49.2
J1	kgm <sup>2</sup>	0.0009	0.0016	0.0028	0.0049	0.0087	0.0155	0.0275	0.0489	0.0870	0.1546	0.2750	0.4890	0.8696	1.5424
ir	-	58.1	58.0	56.3	59.2	60.2	57.2	58.1	58.0	56.3	59.2	60.2	57.2	57.2	57.6
J1	kgm <sup>2</sup>	0.0008	0.0014	0.0026	0.0045	0.0081	0.0143	0.0255	0.0454	0.0806	0.1434	0.2550	0.4535	0.8064	1.4303
ir	-	63.3	63.1	66.3	64.4	65.6	62.3	63.3	63.1	66.3	64.4	65.6	68.1	62.3	62.8
J1	kgm <sup>2</sup>	0.0007	0.0013	0.0024	0.0042	0.0074	0.0132	0.0235	0.0418	0.0743	0.1322	0.2350	0.4179	0.7431	1.3180
ir	-	69.2	69.1	72.5	70.5	71.7	68.1	69.2	69.1	72.5	70.5	71.7	75.0	68.2	68.7
J1	kgm <sup>2</sup>	0.0007	0.0012	0.0022	0.0038	0.0068	0.0121	0.0215	0.0382	0.0680	0.1209	0.2150	0.3823	0.6799	1.2059
ir	-	81.5	81.3	79.8	77.6	84.4	80.2	81.5	81.3	78.9	83.0	79.0	80.2	75.1	81.2
J1	kgm <sup>2</sup>	0.0007	0.0012	0.0021	0.0037	0.0065	0.0153	0.0205	0.0365	0.0648	0.1153	0.2050	0.3646	0.6483	1.1499
ir	-	88.7	88.5	93.0	90.3	92.0	87.3	88.7	88.5	93.0	90.3	92.0	95.6	88.6	88.4
J1	kgm <sup>2</sup>	0.0006	0.0011	0.0020	0.0035	0.0062	0.0110	0.0195	0.0347	0.0617	0.1097	0.1950	0.3468	0.6166	1.0937
ir	-	97.1	96.8	101.7	98.9	100.6	95.6	97.1	96.8	101.7	98.9	100.6	105.2	106.7	96.7
J1	kgm <sup>2</sup>	0.0006	0.0010	0.0019	0.0033	0.0059	0.0104	0.0185	0.0329	0.0585	0.1040	0.1850	0.3290	0.5850	1.0376
ir	-	106.9	106.6	111.9	108.8	110.7	105.2	106.9	106.6	111.9	108.8	110.7	116.5	118.2	106.4
J1	kgm <sup>2</sup>	0.0006	0.0010	0.0018	0.0031	0.0055	0.0098	0.0175	0.0311	0.0553	0.0984	0.1750	0.3112	0.5534	0.9816
ir	-	118.4	118.0	123.9	120.5	122.7	116.5	118.4	118.0	123.9	120.5	122.7	130.2	132.0	117.8
J1	kgm <sup>2</sup>	0.0006	0.0010	0.0017	0.0031	0.0055	0.0097	0.0173	0.0308	0.0547	0.0973	0.1730	0.3076	0.5471	0.9704

Se è richiesto il momento d'inerzia dell'entrata supplementare contattare il servizio tecnico GSM.

*If you need to know the moment of inertia of the auxiliary drive unit, please contact STM Engineering.*

Falls die Wertangabe des Trägheitsmoments am zusätzlichen Antrieb erforderlich sein sollte, kann sie bei der Technischen Abteilung der STM angefragt werden.

## 1.10 Motori applicabili

## 1.10 Compatible motors

## 1.10 Applizierbare Motoren

		IEC													
		71	80	90	100	112	132	160	180	200	225	250	280	315	355
<b>RX02 - RXV2</b>	802														
	804														
	806														
	808														
	810														
	812														
	814														
	816														
	818														
	820														
	822.. 828	A richiesta / On request / Auf Anfrage													

**Possibili accoppiamenti con motori IEC**  
**Possible couplings with IEC motors**  
**Mögliche Verbindungen mit IEC-Motoren**

	IEC	ir	
		Tutti / All / Alle	
<b>O 71</b>	63	11/140 (B5)	
	71	14/160 (B5)	14/200 - 14/140 - 14/120
	80	19/200 (B5) - 19/120 (B14)	19/160 - 19/140
	90	24/200 (B5) - 24/140 (B14)	24/160 - 24/120
	100	28/250 (B5) - 28/160 (B14)	
	112	28/250 (B5) - 28/160 (B14)	
<b>O 90</b>	71	14/160 (B5)	
	80	19/200 (B5)	
	90	24/200 (B5)	24/300 - 24/250
	100	28/250 (B5) - 28/160 (B14)	28/200 - 28/300
	112	28/250 (B5) - 28/160 (B14)	28/200 - 28/300
	132	38/300 (B5) - 38/200 (B14)	38/250
<b>O 112</b>	80	19/200 (B5)	
	90	24/200 (B5)	
	100	28/250 (B5)	28/350 - 28/300
	112	28/250 (B5)	28/350 - 28/300
	132	38/300 (B5)	38/350 - 38/250
	160	42/350 (B5)	42/300 - 42/250

		Possibili accoppiamenti con motori IEC <i>Possible couplings with IEC motors</i> Mögliche Verbindungen mit IEC-Motoren
IEC		ir Tutti / <u>All</u> / <u>Alle</u>
		11/140 (B5)
		14/160 (B5)
		19/200 (B5)
O 125	90	24/200 (B5)
	100	28/250 (B5)
	112	28/250 (B5)
	132	38/300 (B5)
	160	42/350 (B5)
	180	48/350 (B5)
	200	55/400 (B5)
O 140	100	28/250 (B5)
	112	28/250 (B5)
	132	38/300 (B5)
	160	42/350 (B5)
	180	48/350 (B5)
	200	55/400 (B5)
	225	55/450 - 60/450 (B5)
O 160	100	28/250 (B5)
	112	28/250 (B5)
	132	38/300 (B5)
	160	42/350 (B5)
	180	48/350 (B5)
	200	55/400 (B5)
	225	55/450 - 60/450 (B5)
	250	60/550 - 65/550 (B5)
O 180	132	38/300 (B5)
	160	42/350 (B5)
	200	55/400 (B5)
	225	55/450 - 60/450 (B5)
	250	60/550 - 65/550 (B5)
	280	65/550 - 75/550 (B5)
O 200	132	38/300 (B5)
	160	42/350 (B5)
	180	48/350 (B5)
	200	55/400 (B5)
	225	55/450 - 60/450 (B5)
	250	60/550 - 65/550 (B5)
	280	65/550 - 75/550 (B5)

Legenda:

**19/200 (B5)**      19/160

**19/200** : combinazioni albero/flangia standard  
 (B5) : forma costruttiva motore IEC  
 19/160 : combinazione albero/flangia a richiesta

Key:

**19/200 (B5)**      19/160

**19/200** : standard shaft/flange combination  
 (B5) : IEC motor constructive shape  
 19/160 : shaft/flange combinations upon request

Legende:

**19/200 (B5)**      19/160

**19/200** : Standardkombinationen Welle/Flansch  
 (B5) : Konstruktionsform IEC-Motor  
 19/160 : Sonderkombinationen Welle/Flansch

**1.11 Dimensioni**

**1.11 Dimensions**

**1.11 Abmessungen**

**802 - 812**

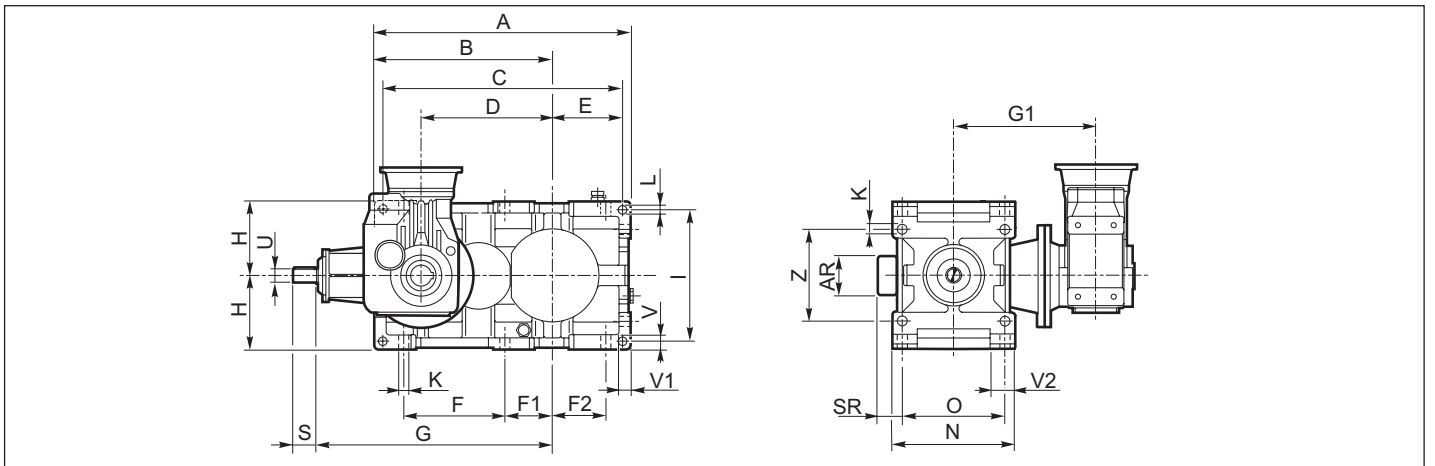

Esecuzione grafica / Shaft arrangement / Grafische Ausführung

Albero uscita / Output shaft / Abtriebswelle

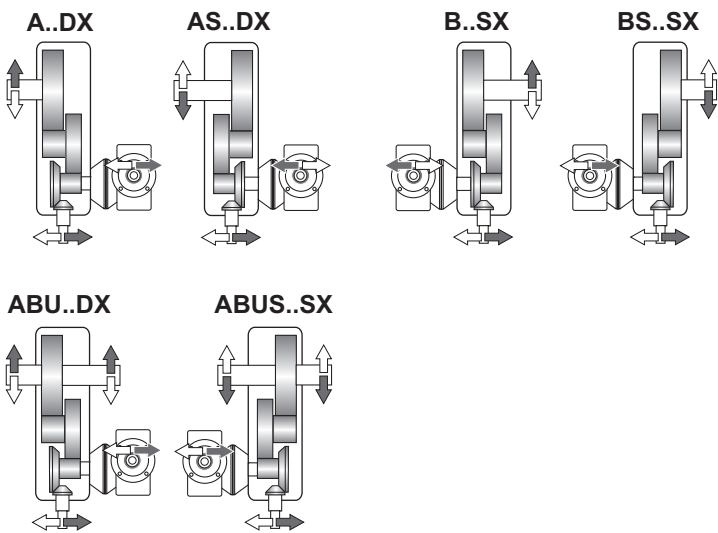

⇒ **N D FD Fn**

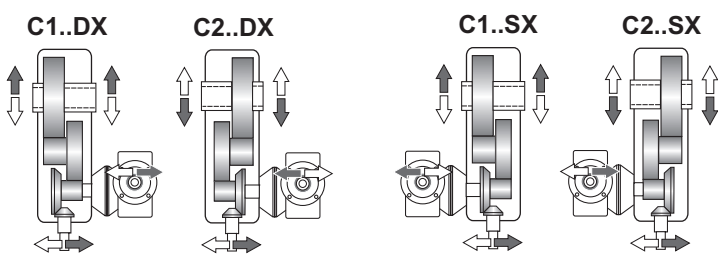
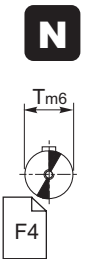
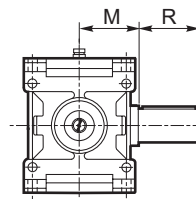

⇒ **C**

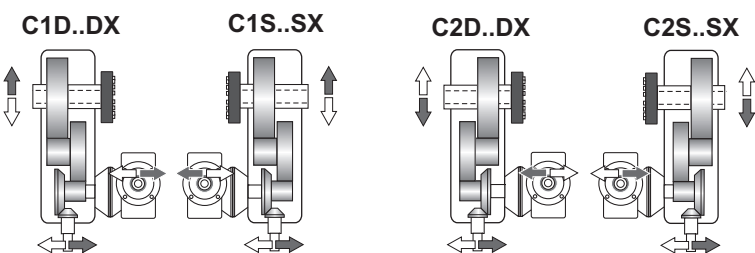
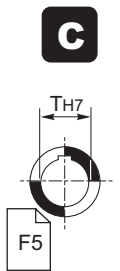
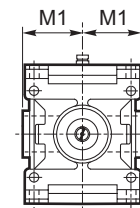

⇒ **UB B**

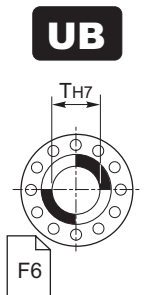
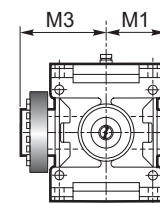



Dimensioni generali / Dimensions / Allgemeine Abmessungen																						
	A	AR	B	C	D	E	F	F1	F2	G1	H <sub>h11</sub>	I	L	N <sub>h11</sub>	O	K	SR	V	V1	V2	Z	Kg
802	435	72	305	407	225	116	172.5	82.5	90	313	125	224	14	213	180	18	41	25	20	44.5	160	112
804	492	80	342	460	252	134	195	91	104	331	140	250	16	237	200	20	57	28	22.5	49	180	149
806	555	90	385	521	285	153	219.5	102.5	117	377	160	280	18	269	225	22	66	32	25	56.5	200	227
808	622	100	432	584	320	171	246	116	130	398	180	320	20	297	250	25	57	36	28	59.5	224	294
810	695	110	485	655	360	190	275	130	145	476	200	360	22	335	280	27	58	40	32	67.5	250	427
812	785	120	545	740	405	217.5	307.5	147.5	160	508	225	400	24	379	315	30	63	45	36	78.5	280	570

	Albero entrata / Input shaft / Antriebswelle			Albero uscita / Output shaft / Abtriebswelle								
	U	S	G									
				T m6	R	M	T H7	M1	T H7	M1	M3	
802	22 j6	40	405	60	112	109	60	109	60	60	109	170
804	24 k6	45	452	70	125	121	70	121	70	70	121	192
806	28 k6	50	510	80	140	137	80	137	80	80	137	215
808	32 k6	56	570	90	160	151	90	151	90	90	151	246
810	35 k6	63	640	100	180	170	100	170	100	100	170	266
812	40 k6	70	720	110	200	192	110	192	110	110	192	302

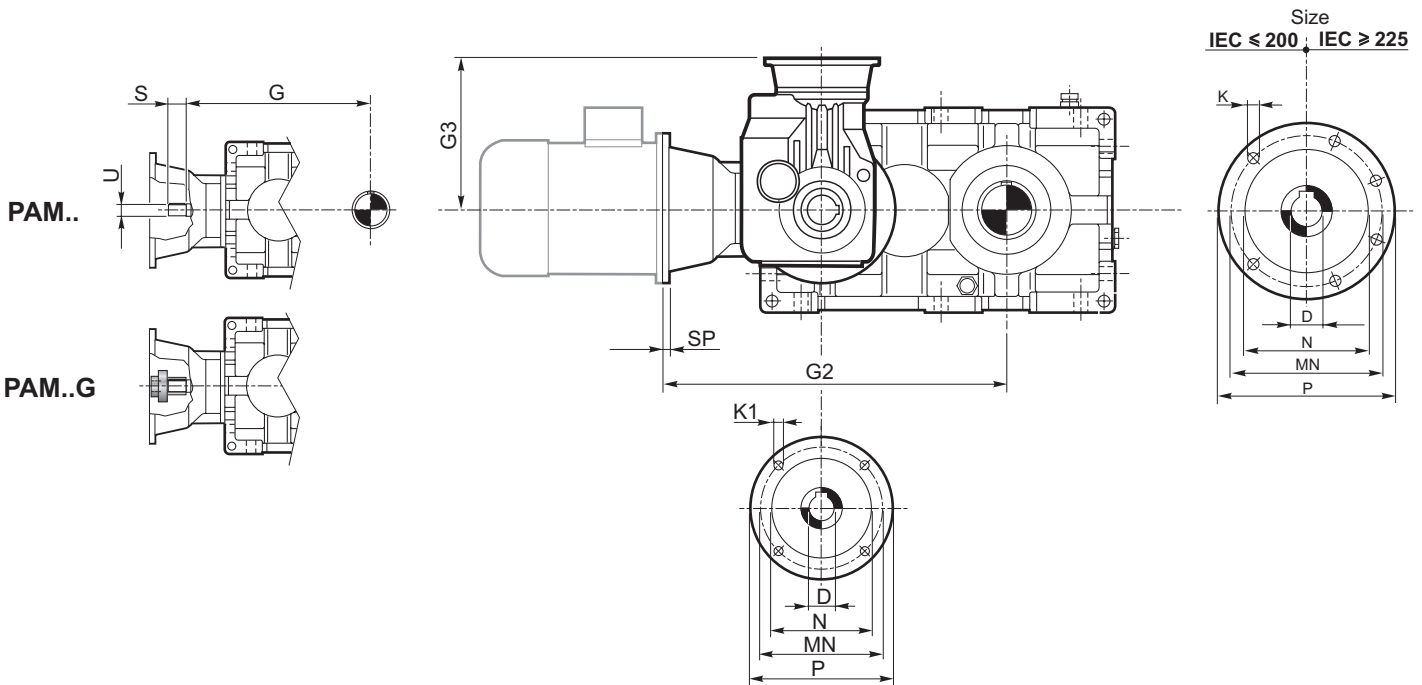

	IEC														
	63	71	80	90	100	112	132	160	180	200	225	250	280	315	355
D H7	11	14	19	24	28	28	38	42	48	55	60	65	75	80	100
P (IECB5)	140	160	200	200	250	250	300	350	350	400	450	550	550	660	800
P (IECB14)	—	—	120	140	160	160	200	—	—	—	—	—	—	—	—
MN	110	130	165	165	215	215	265	300	300	350	400	500	500	600	740
N G6	95	110	130	130	180	180	230	250	250	300	350	450	450	550	680
K		M8	M10	M10	M12	M12	M12	M16	M16	M16	M16	M16	M16	M16	M20
K1															
SP		12	12	12	14	14	16	18	18	20	20	20	20	24	30
G2	802				499	509	509	529	559	559	559				
	804					561	561	581	611	611	611	641			
	806					624	624	644	674	674	674	704			
	808							710	740	740	740	770	770	770	
	810							787	817	817	817	847	847	847	877
	812							874	904	904	904	934	934	934	964
G3	802	217	217	237	237	247	247								
	804	217	217	B5-B14	B5-B14	B5-B14	B5-B14								
	806		249	264	264	274	274	300							
	808		249	264	264	B5-B14	B5-B14	B5-B14							
	810			304	304	319	319	340	370						
	812			304	304	319	319	340	370						

814 - 820

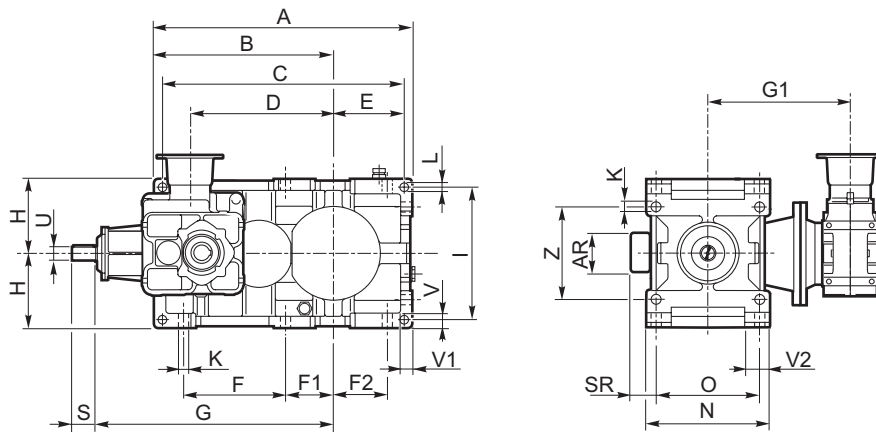

Esecuzione grafica / Shaft arrangement / Grafische Ausführung

Albero uscita / Output shaft / Abtriebswelle

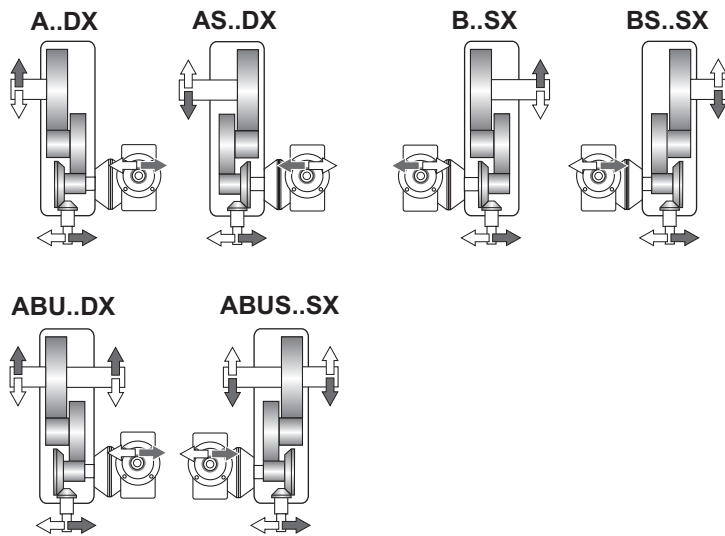

⇒ **N D FD Fn**

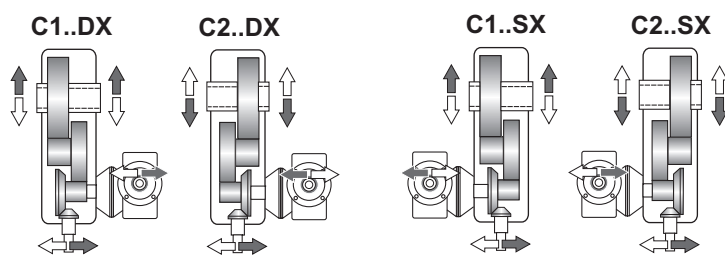
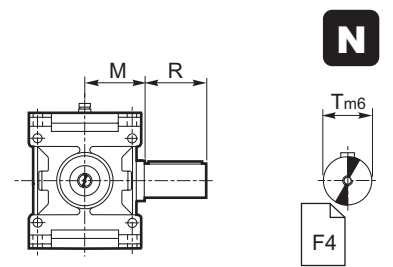

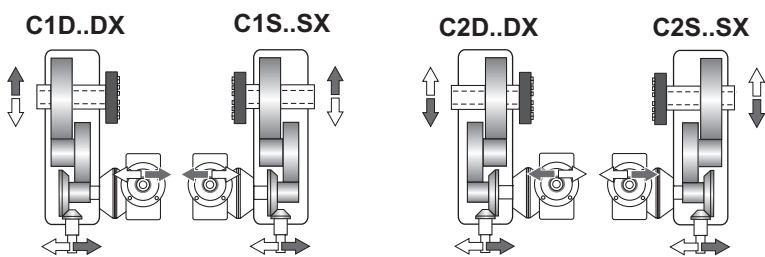
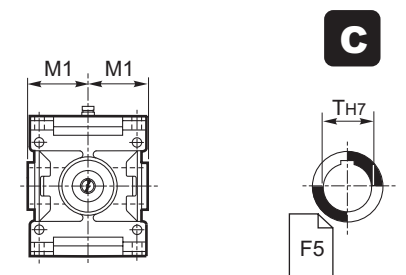

⇒ **C**

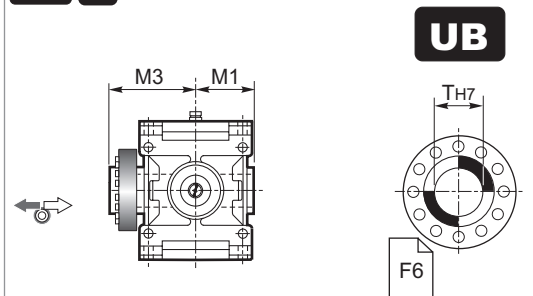

⇒ **UB B**



Dimensioni generali / Dimensions / Allgemeine Abmessungen																						
	A	AR	B	C	D	E	F	F1	F2	G1	H <sub>h11</sub>	I	L	N <sub>h11</sub>	O	K	SR	V	V1	V2	Z	Kg
<b>814</b>	875	130	610	825	495	240	345	165	180	607	250	450	27	427	355	33	86	50	40	89	320	803
<b>816</b>	985	150	685	929	550	272	388	185	203	645	280	500	30	479	400	36	81	56	45	96.5	360	1084
<b>818</b>	1110	170	770	1046	610	308	437.5	207.5	230	717	315	560	35	541	450	39	67	63	50	114.5	400	1517
<b>820</b>	1245	180	865	1173	680	344	492.5	232.5	260	761	355	638	39	599	500	42	97	70	56	124	450	2069

	Albero entrata / Input shaft / Antriebswelle			Albero uscita / Output shaft / Abtriebswelle								
	U	S	G									
				T m6	R	M	T H7	M1	T H7	M1	M3	
<b>814</b>	45 k6	80	805	125	225	216	125	216	125	216	335	
<b>816</b>	50 k6	90	905	140	250	242	140	242	140	242	370	
<b>818</b>	55 m6	100	1020	160	280	273	160	273	160	273	422	
<b>820</b>	60 m6	112	1140	180	315	302	180	302	180	302	477	

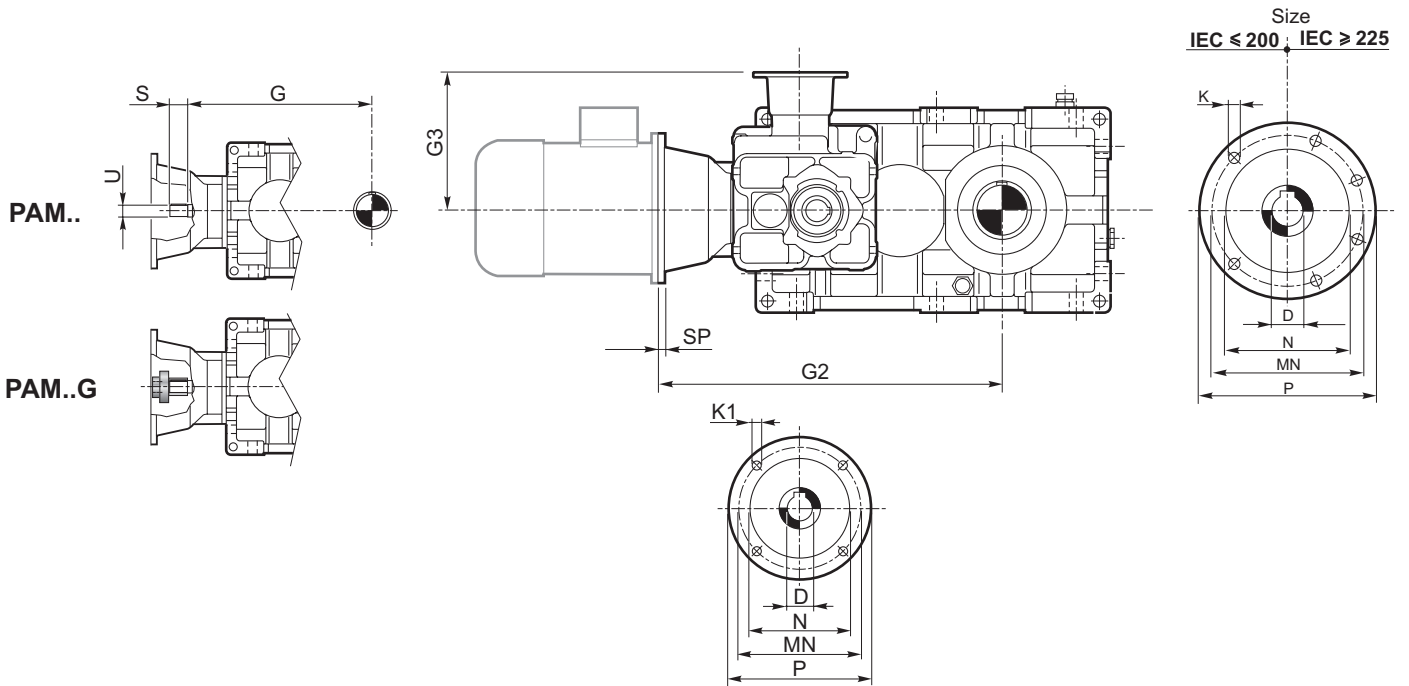

	IEC														
	63	71	80	90	100	112	132	160	180	200	225	250	280	315	355
<b>D H7</b>	11	14	19	24	28	28	38	42	48	55	60	65	75	80	100
<b>P (IECB5)</b>	140	160	200	200	250	250	300	350	350	400	450	550	550	660	800
<b>MN</b>	110	130	165	165	215	215	265	300	300	350	400	500	500	600	740
<b>N G6</b>	95	110	130	130	180	180	230	250	250	300	350	450	450	550	680
<b>K</b>		M8	M10	M10	M12	M12	M12	M16	M16	M16	M16	M16	M16	M16	M20
<b>K1</b>															
<b>SP</b>		12	12	12	14	14	16	18	18	20	20	20	20	24	30
<b>G2</b>	814							999	999	999	1029	1029	1029	1059	
	816							1109	1109	1109	1139	1139	1139	1169	1209
	818									1234	1264	1264	1264	1294	1334
	820										1396	1396	1396	1426	1466
<b>G3</b>	814			357	357	367	367	387	417	417	417				
	816			357	357	367	367	387	417	417	417				
	818					401.5	401.5	421.5	451.5	451.5	451.5	481.5			
	820					401.5	401.5	421.5	451.5	451.5	451.5	481.5			

822 - 828

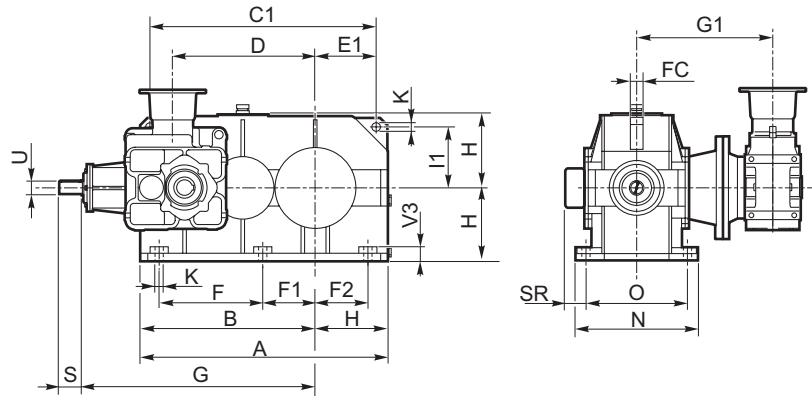

Esecuzione grafica / Shaft arrangement / Grafische Ausführung

Albero uscita / Output shaft / Abtriebswelle

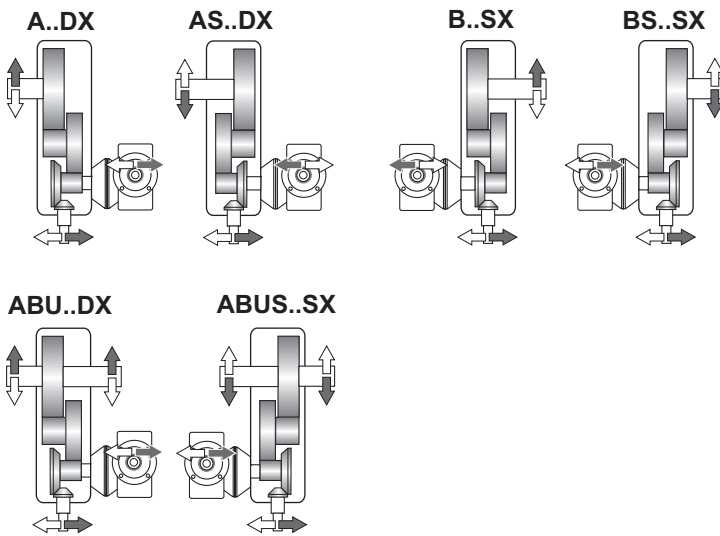

⇒ **N D FD Fn**

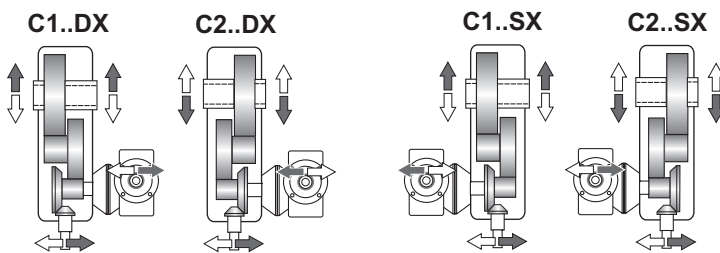
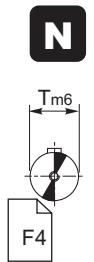
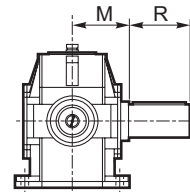

⇒ **C**

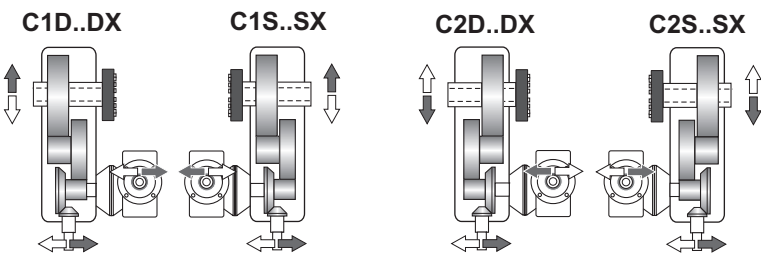
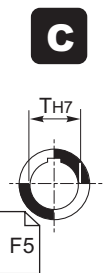
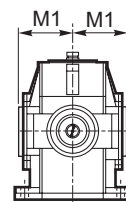

⇒ **UB B**

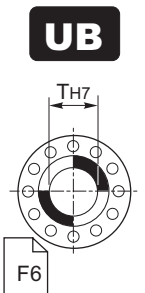
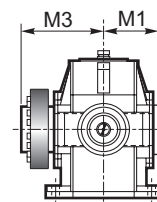

Dimensioni generali / Dimensions / Allgemeine Abmessungen																			
	A	AR	B	D	C1	E1	F	F1	F2	FC	G1	H h11	I1	K	N h11	O	SR	V3	Kg
822	1370	*	970	780	1240	335	570	300	300	60	734	400	335	45	675	560	*	55	2879
824	1540	*	1090	878	1410	385	640	320	320	60	847	450	385	48	761	630	*	60	3483
826	1715	*	1215	975	1565	425	715	365	365	70	914	500	425	52	855	710	*	65	4837
828	1925	*	1365	1085	1755	475	805	415	415	2x50	994	560	475	56	965	800	*	80	6636

	Albero entrata / Input shaft / Antriebswelle			Albero uscita / Output shaft / Abtriebswelle								
	U	S	G									
				T m6	R	M	T H7	M1	T H7	M1	M3	
822	70 m6	125	1280	200	355	340	200	340	200	340	*	
824	80 m6	140	1400	220	400	383	220	383	220	383	*	
826	90 m6	160	1610	250	450	430	250	430	250	430	*	
828	100 m6	180	1820	280	500	485	280	485	280	785	*	

\* A richiesta / On request / Auf Anfrage

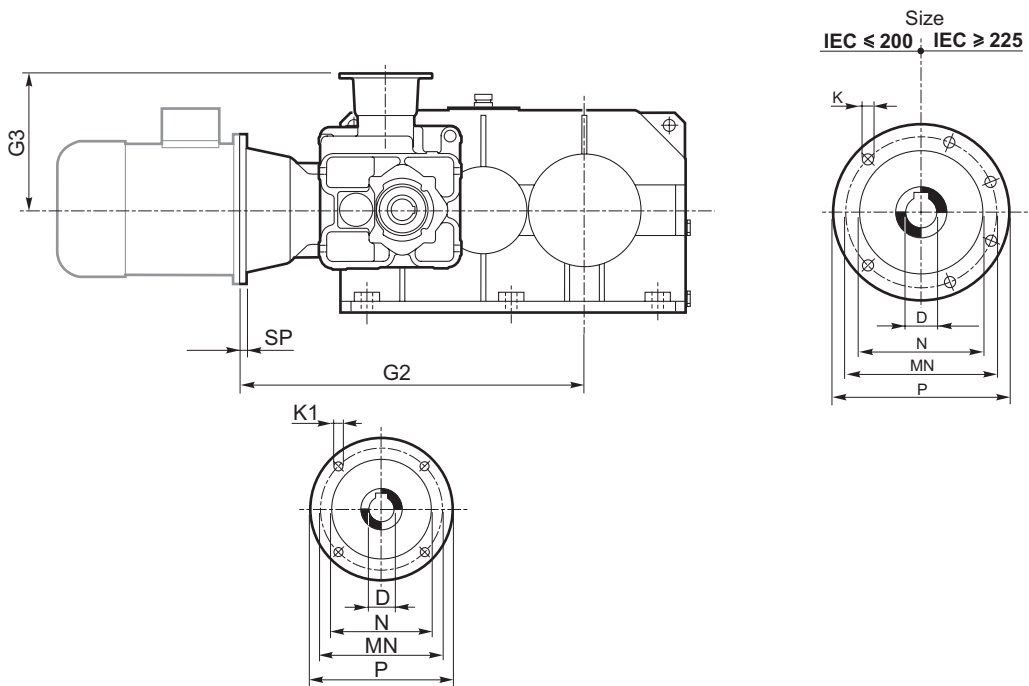

	IEC															
	63	71	80	90	100	112	132	160	180	200	225	250	280	315	355	
D H7	11	14	19	24	28	28	38	42	48	55	60	65	75	80	100	
P (IECB5)	140	160	200	200	250	250	300	350	350	400	450	550	550	660	800	
MN	110	130	165	165	215	215	265	300	300	350	400	500	500	600	740	
N G6	95	110	130	130	180	180	230	250	250	300	350	450	450	550	680	
K		M8	M10	M10	M12	M12	M12	M16	M16	M16	M16	M16	M16	M16	M20	
K1																
SP		12	12	12	14	14	16	18	18	20	20	20	20	24	30	
G2	822-826	A richiesta / On request / Auf Anfrage														
G3	822				425	425	445	475	475	475	505	505	505			
	824						415	433	433	433	463	464	464			
	826						443	461	461	461	491	492	492			
	828						443	461	461	461	491	492	492			

